

***TTP-2410M/346M***

***TTP-246M Plus/344M Plus***

**THERMAL TRANSFER / DIRECT THERMAL  
BAR CODE PRINTER**

**USER'S  
MANUAL**

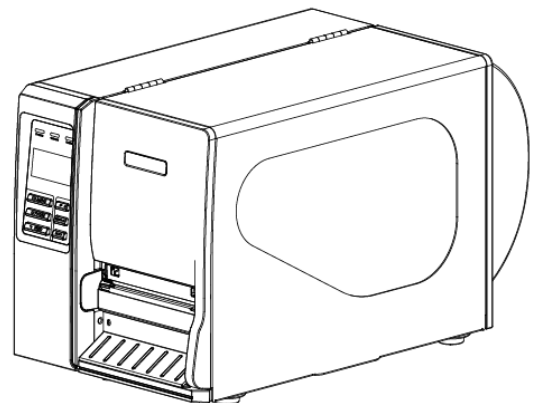

# Contents

|   |           |
|---|-----------|
| <b>1. Introduction</b> .....                                | <b>1</b>  |
| <b>1.1 Product Introduction</b> .....                       | <b>1</b>  |
| <b>1.2 Compliances</b> .....                                | <b>1</b>  |
| <b>2. Operations Overview</b> .....                         | <b>3</b>  |
| <b>2.1 Unpacking and Inspection</b> .....                   | <b>3</b>  |
| <b>2.2 Printer Overview</b> .....                           | <b>4</b>  |
| <b>2.2.1 Front View</b> .....                               | <b>4</b>  |
| <b>2.2.2 Interior view</b> .....                            | <b>5</b>  |
| <b>2.2.3 Rear View</b> .....                                | <b>6</b>  |
| <b>2.3 Operator Controls</b> .....                          | <b>7</b>  |
| <b>2.3.1 Front Panel Display</b> .....                      | <b>7</b>  |
| <b>2.3.2 LED Indicators</b> .....                           | <b>7</b>  |
| <b>2.3.3 Front Panel Keys</b> .....                         | <b>8</b>  |
| <b>2.4 Setting Up the Printer</b> .....                     | <b>8</b>  |
| <b>2.5 Installation of Ribbon</b> .....                     | <b>9</b>  |
| <b>2.5.1 Loading Ribbon</b> .....                           | <b>9</b>  |
| <b>2.5.2 Remove Used Ribbon</b> .....                       | <b>12</b> |
| <b>2.6 Installation of Media</b> .....                      | <b>13</b> |
| <b>2.6.1 Loading Roll Labels</b> .....                      | <b>13</b> |
| <b>2.6.2 Loading Fan-fold Labels</b> .....                  | <b>16</b> |
| <b>2.6.3 Loading Media for Peel-off Mode (Option)</b> ..... | <b>18</b> |
| <b>2.6.4 Remove Liner (Option)</b> .....                    | <b>20</b> |
| <b>2.7 Adjustment Knob</b> .....                            | <b>21</b> |
| <b>2.7.1 Print head Pressure Adjustment Knob</b> .....      | <b>21</b> |
| <b>2.7.2 Print Head Burn Line Adjustment Knob</b> .....     | <b>21</b> |
| <b>3. Menu Function</b> .....                               | <b>23</b> |
| <b>3.1 Setup Menu Overview</b> .....                        | <b>24</b> |
| <b>3.1.1 Printer Setup</b> .....                            | <b>25</b> |
| <b>3.1.2 Sensor</b> .....                                   | <b>32</b> |
| <b>3.1.3 Serial Comm.</b> .....                             | <b>36</b> |
| <b>3.1.4 Ethernet</b> .....                                 | <b>38</b> |
| <b>3.2 File Manager</b> .....                               | <b>41</b> |
| <b>3.2.1 File List</b> .....                                | <b>41</b> |
| <b>3.2.2 Avail. Memory</b> .....                            | <b>41</b> |
| <b>3.2.3 Del. All Files</b> .....                           | <b>41</b> |

|                                   |           |
|-----------------------------------|-----------|
| <b>3.3 Diagnostics .....</b>      | <b>42</b> |
| <b>3.3.1 Print Config. ....</b>   | <b>42</b> |
| <b>3.3.2 Dump Mode .....</b>      | <b>43</b> |
| <b>3.3.3 Rotate Cutter .....</b>  | <b>44</b> |
| <b>3.4 Language.....</b>          | <b>44</b> |
| <b>3.5 Service.....</b>           | <b>45</b> |
| <b>3.5.1 Initialization .....</b> | <b>45</b> |
| <b>3.5.2 Mileage Info.....</b>    | <b>46</b> |
| <b>4. Troubleshooting .....</b>   | <b>47</b> |
| <b>5. Maintenance .....</b>       | <b>49</b> |
| <b>Revise History .....</b>       | <b>50</b> |

# 1. Introduction

## 1.1 Product Introduction

Thank you very much for purchasing TSC bar code printer.

This printer is designed with die-casting aluminum chassis and print mechanism, metal cover with large clear media view window, which ensuring to work for the extreme and heavy duty industrial environment and applications.

With back-lit graphic LCD display, printer status can be managed easier and operated more user friendly. The moveable sensor design can accept wide range of label media. All of the most frequently used bar code formats are included. Fonts and bar codes can be printed in any one of the four directions. This printer is built-in the high quality, high performance MONOTYPE IMAGING® True Type font engine and one CG Triumvirate Bold Condensed smooth font. With flexible firmware design, user can also download the True Type Font from PC into printer memory for printing labels. Besides the scalable font, It also provides a choice of five different sizes of alphanumeric bitmap font, OCR-A and OCR-B fonts. By integrating rich features, it is the most cost-effective and high performance printer in its class!

## 1.2 Compliances

CE Class A:

EN55022:1998+A1:2000+A2:2003:

EN55024:1998+A1:2001+A2:2003:

EN 61000-4 SERIES REGULATIONS

ETSI EN 301 489-17:V1.2.1(2002-08)

FCC:

CFR 47, Part 15/CISPR 22 3RD EDITION:1997, Class A

|  |
|--|
| <p>This device complies with Part 15 of the FCC Rules.<br/>Operation is subject to the following two conditions.<br/>(1)This device may not cause harmful interference, and<br/>(2)This device must accept any interference received,<br/>including interference that may cause undesired operation.</p> |
|--|

ANSI C63.4:2003

CANADIAN ICES-003

C-Tick:

AS/NZS CISPR22 (Class A)

UL, CUL  
UL 60950 3<sup>rd</sup>  
TÜV-GS:  
EN60950: 2000

#### Wichtige Sicherheits-Hinweise

1. Bitte lesen Sie Diese Hinweis sorgfältig durch
2. Heben Sie diese Anleitung für den späteren Gebrauch auf.
3. Vor jedem Reinigen ist das Gerät vom Stromnetz zu trennen. Verwenden Sie Keine Flüssig-oder Aerosolreiniger. Am besten eignet sich ein angefeuchtetes Tuch zur Reinigung.
4. Die Netzanschlußsteckdose soll nahe dem Gerät angebracht und leicht zugänglich sein.
5. Das Gerät ist vor Feuchtigkeit zu schützen.
6. Bei der Aufstellung des Gerätes ist auf sicheren Stand zu achten. Ein Kippen oder Fallen könnte Beschädigungen hervorrufen.
7. Beachten Sie beim Anschluß an das stromnetz die Anschlußwerte.
8. Dieses das Gerät kann bis zu einer Außentemperatur von maximal 40°C betrieben werden.

(CAUTION: Danger of explosion if battery is incorrectly replaced. Replace only with the same or equivalent type recommended by the manufacturer. Dispose of used batteries according to the manufacturer instructions.)

#### "ORSICHT"

Explosionsgefahr bei unsachgemäßen Austausch der Batterie. Ersatz nur durch denselben oder einem vom Hersteller empfohlenen nlichen Typ. Entsorgung gebrauchter Batterien nach Angaben des Herstellers.

## 2. Operations Overview

### 2.1 Unpacking and Inspection

This printer has been specially packaged to withstand damage during shipping. Please carefully inspect the packaging and printer upon receiving the bar code printer. Please retain the packaging materials in case you need to reship the printer.

Unpacking the printer, the following items are included in the carton.

- One printer unit
- One Windows labeling software/Windows driver CD disk
- One quick installation guide
- One power cord
- One USB interface cable

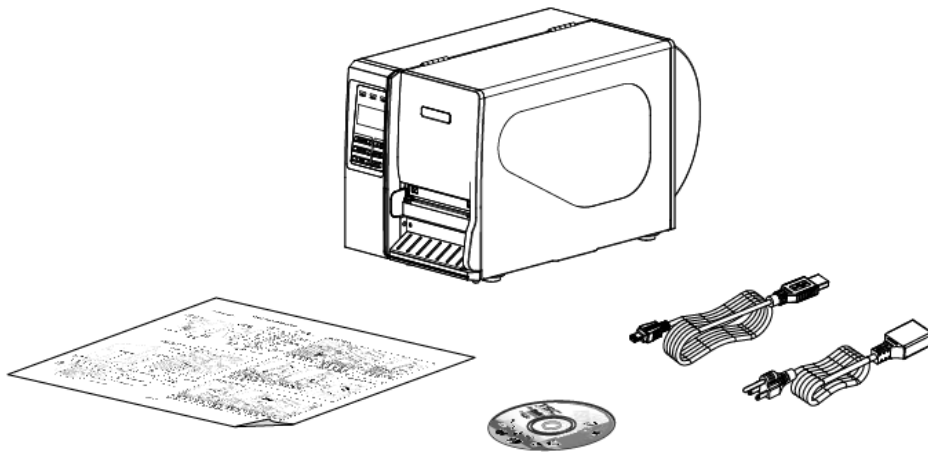

If any parts are missing, please contact the Customer Service Department of your purchased reseller or distributor.

## 2.2 Printer Overview

### 2.2.1 Front View



1. LED indicators
2. LCD display
3. Front panel buttons
4. Paper exit chute
5. Lower front cover
6. Printer right side cover

## 2.2.2 Interior view

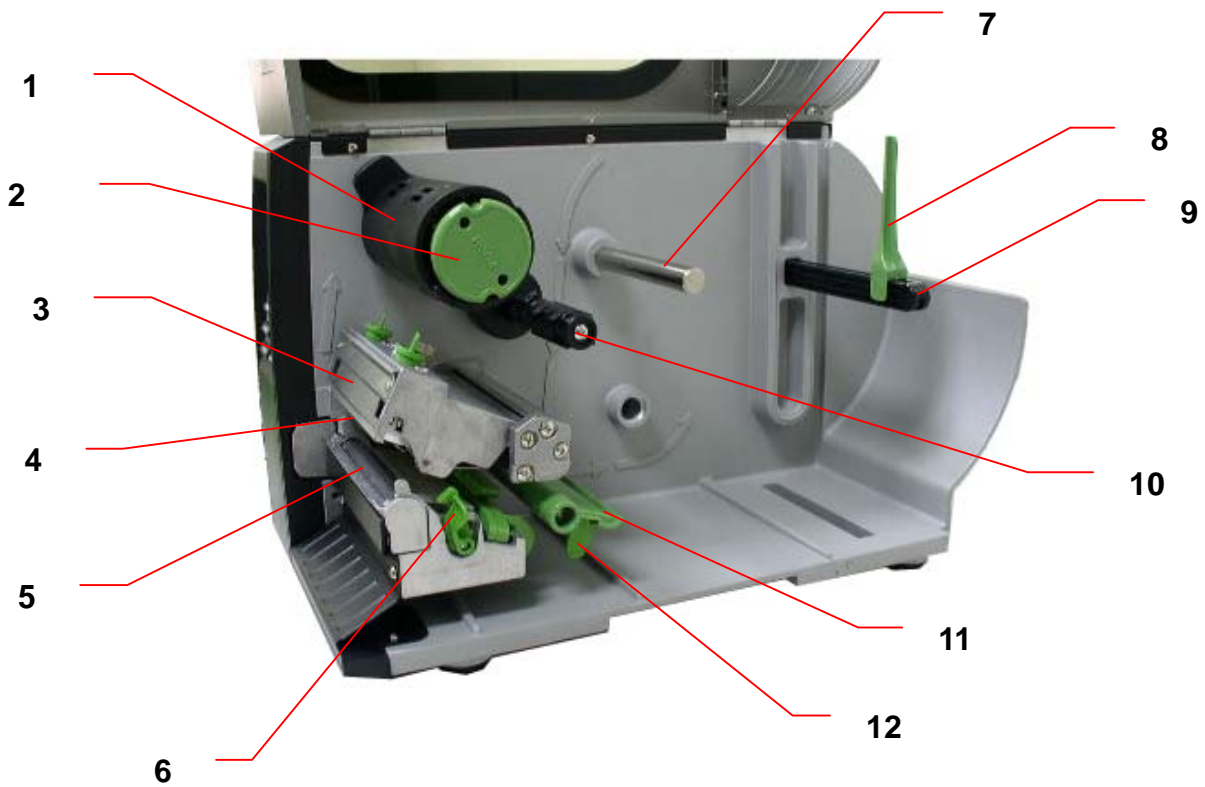

1. Ribbon rewind spindle
2. Ribbon release button
3. Ribbon guide plate
4. Print head
5. Platen roller
6. Print head release lever
7. Media guide bar
8. Label roll guard
9. Label supply spindle
10. Ribbon supply spindle
11. Damper
12. Label guide
13. Z axis mechanism adjustment knob
14. Print head pressure adjustment knob
15. Print head secure screw
16. Ribbon sensor
17. Media sensor

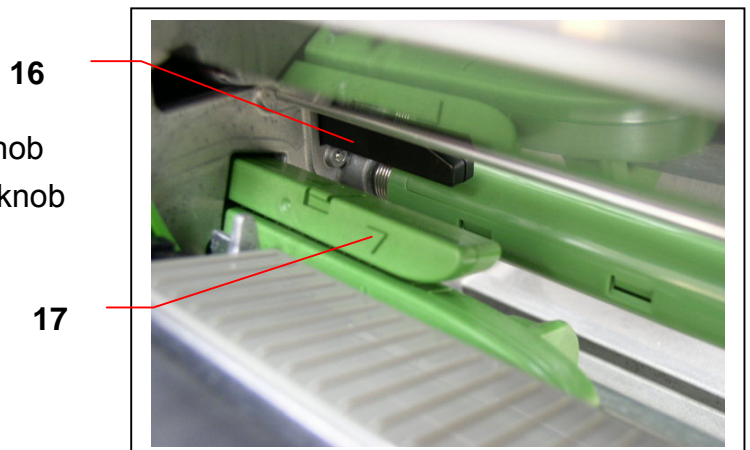
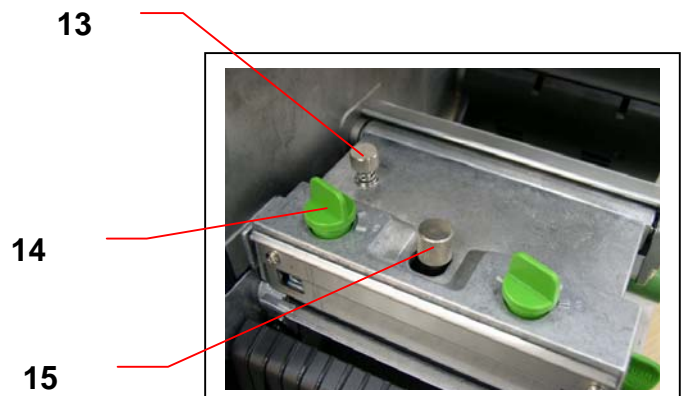

## 2.2.3 Rear View



1. Fan-fold paper entrance chute
2. Centronics interface
3. USB interface
4. RS-232C interface
5. Power jack socket
6. GPIO interface
- \*7. SD card slot
8. Ethernet interface
9. PS/2 interface
10. Power switch

**Note:**

1. SD card slot, Ethernet interface and PS/2 interface are standard interfaces for TTP-2410M/TTP-346M models, but optional for TTP-246M Plus/TTP-344M Plus models.
2. GPIO interface card includes SD card slot, Ethernet and PS/2 interfaces. So GPIO interface is a factory option for TTP-2410M/TTP-346M, but a dealer option for TTP-246M Plus/TTP-344M Plus models.

\* Recommended SD card specification. (Sandisk, Transcend)

| SD V 1.0, V 1.1  | SD V 2.0 (SDHC) |
|--|-----------------|
| ✓ 128MB  | ✓ 4GB class 6   |
| ✓ 256MB  |                 |
| ✓ 512MB  |                 |
| ✓ 1GB  |                 |
| -Supported DOS FAT file system.                                      |                 |
| -Folders stored on the SD card should be in the 8.3 filename format. |                 |

## 2.3 Operator Controls



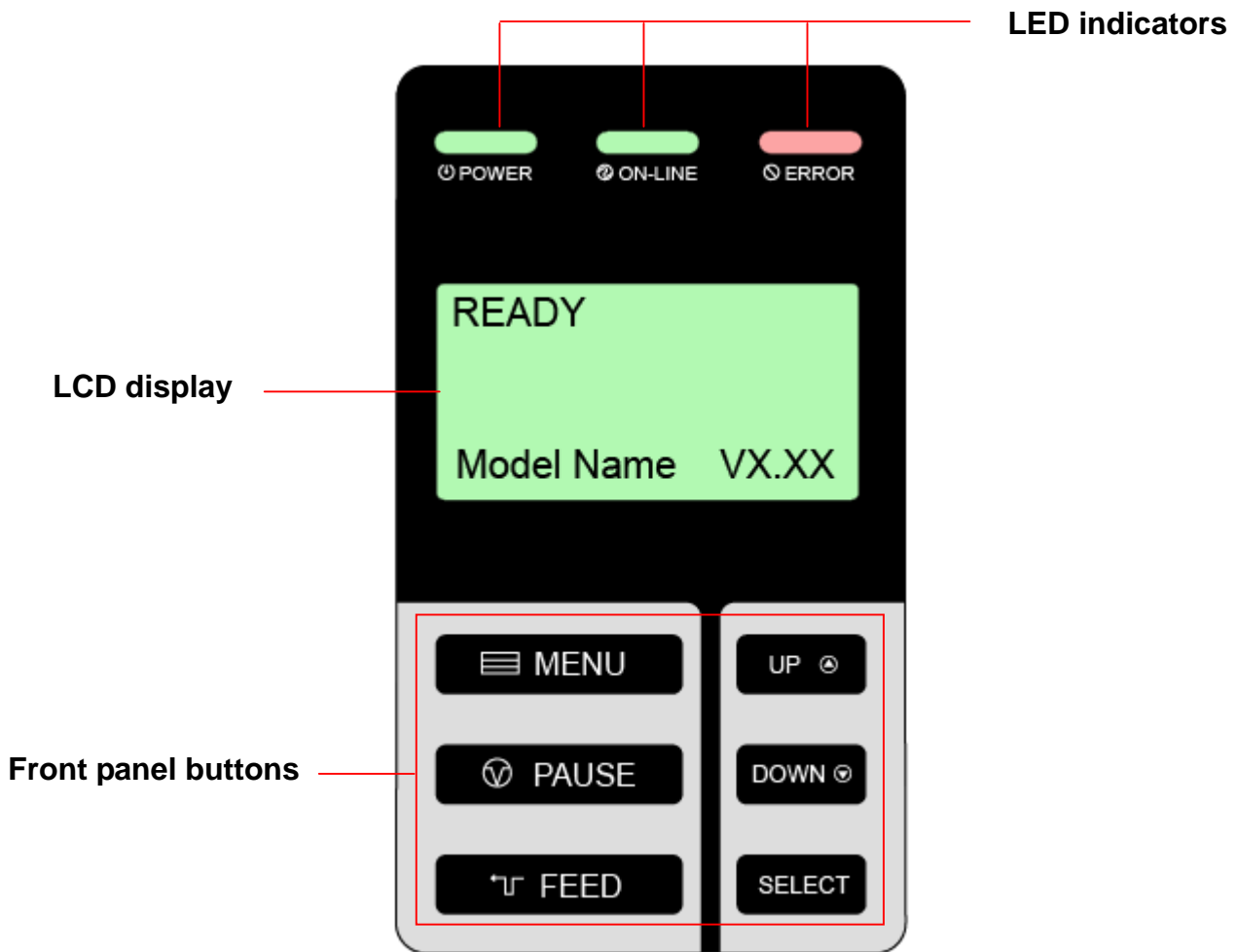

### 2.3.1 Front Panel Display



### 2.3.2 LED Indicators

| LED       | Status   | Indication                              |
|-----------|----------|---|
| ⏻ POWER   | Off      | The printer power is turned off         |
|           | On       | The printer power is turned on          |
| 🟢 ON-LINE | On       | Printer is ready                        |
|           | Blinking | Pause<br>Downloading data into printer. |
| 🔴 ERROR   | Off      | Printer is ready                        |
|           | On       | "CARRIAGE OPEN" or "CUTTER ERROR"       |
|           | Blinking | "NO PAPER", "PAPER JAM" or "NO RIBBON"  |

### 2.3.3 Front Panel Keys

| Keys   | Function   |
|--|--|
|  <b>MENU</b>  | 1. Enter the menu<br>2. Exit from a menu or cancel a setting and return to the previous menu |
|  <b>PAUSE</b> | Pause/Resume the printing process  |
|  <b>FEED</b>  | Advance one label  |
| <b>UP</b>     | Scroll up the menu list  |
| <b>DOWN</b>   | Scroll down the menu list  |
| <b>SELECT</b>  | Enter/Select cursor located option   |

## 2.4 Setting Up the Printer

1. Place the printer on a flat, secure surface.
2. Make sure the power switch is off.
3. Connect the printer to the computer with the provided USB cable.
4. Plug the power cord into the AC power cord socket at the rear of the printer, and then plug the power cord into a properly grounded power outlet.

## 2.5 Installation of Ribbon

### 2.5.1 Loading Ribbon

1. Lift open printer right side cover.
2. Push the print head release lever to open the print head mechanism.



3. Install the ribbon onto the ribbon supply spindle.

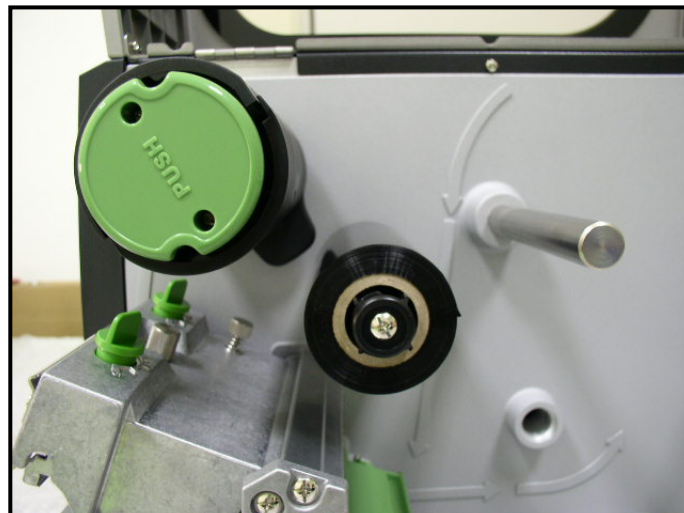

4. Thread the ribbon through the ribbon sensor slot and then through the open space in between print head and platen.

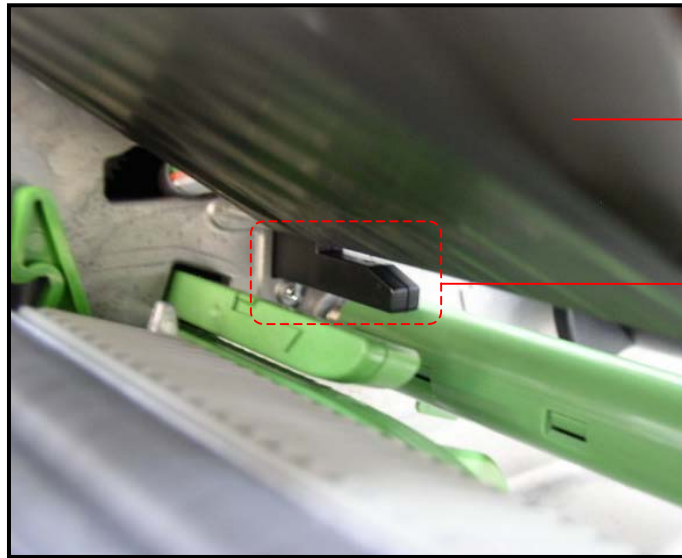

Ribbon

Ribbon  
sensor

5. Wrap the ribbon onto the ribbon rewind spindle. Keeping the ribbon flat and without wrinkles.
6. Wind the ribbon clockwise about 3~5 circles onto the ribbon rewind spindle until it is smooth and properly stretched.

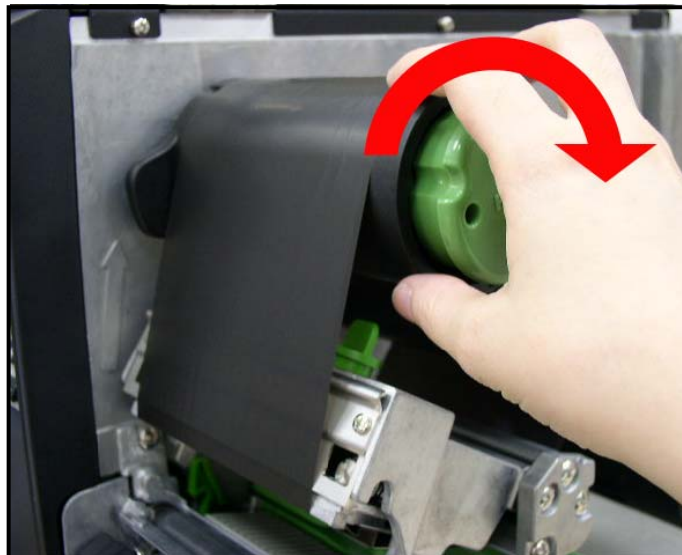

7. Close the print head mechanism making sure the latches are engaged properly.

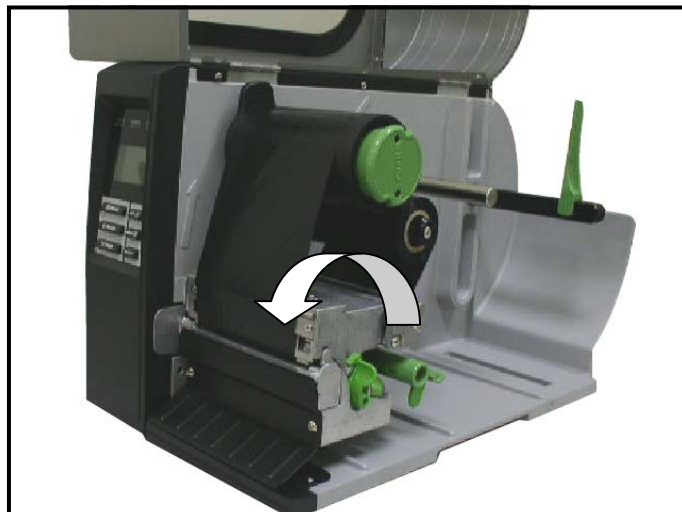

- Loading path for ribbon

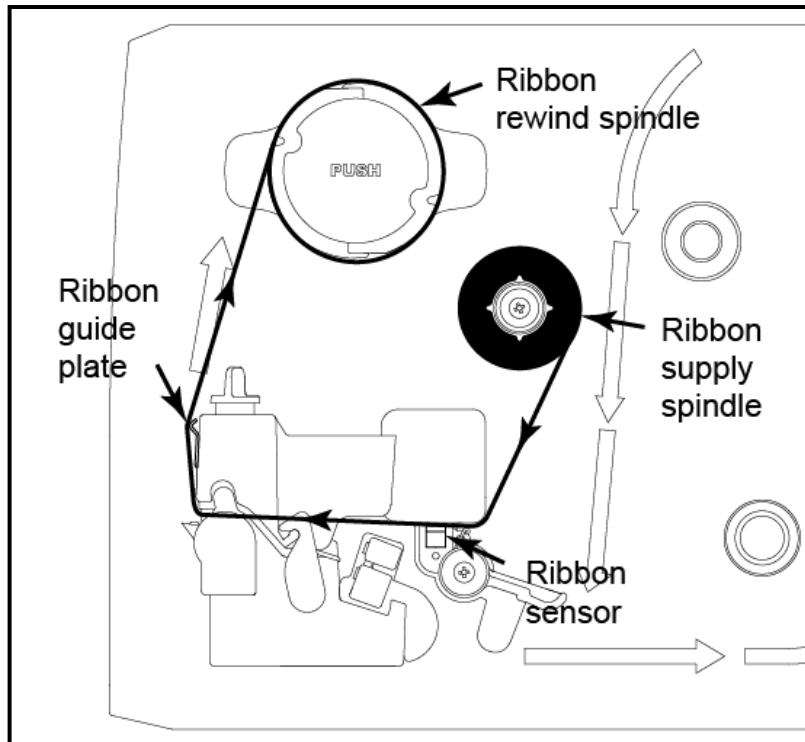

## 2.5.2 Remove Used Ribbon

1. Break the ribbon between ribbon guide plate and the ribbon rewind spindle.

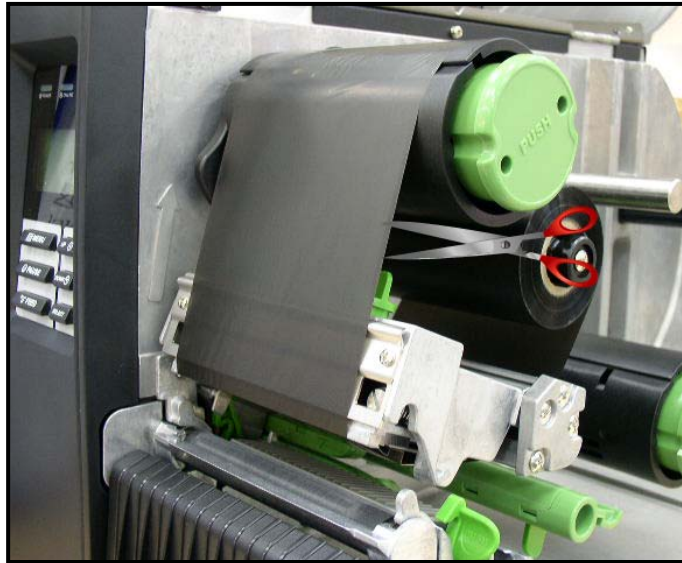

2. Push the ribbon release button to release the ribbon on the ribbon rewind spindle.



3. Then, slide off the ribbon from ribbon rewind spindle.



## 2.6 Installation of Media

### 2.6.1 Loading Roll Labels

1. Lift open printer right side cover.
2. Push the print head release lever to open the print head mechanism.

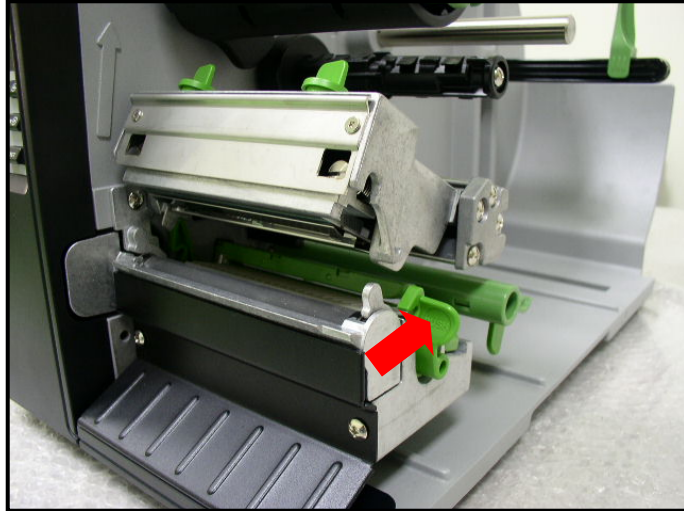

3. Move the label roll guard horizontally to the end of label spindle then flip down the label roll guard.

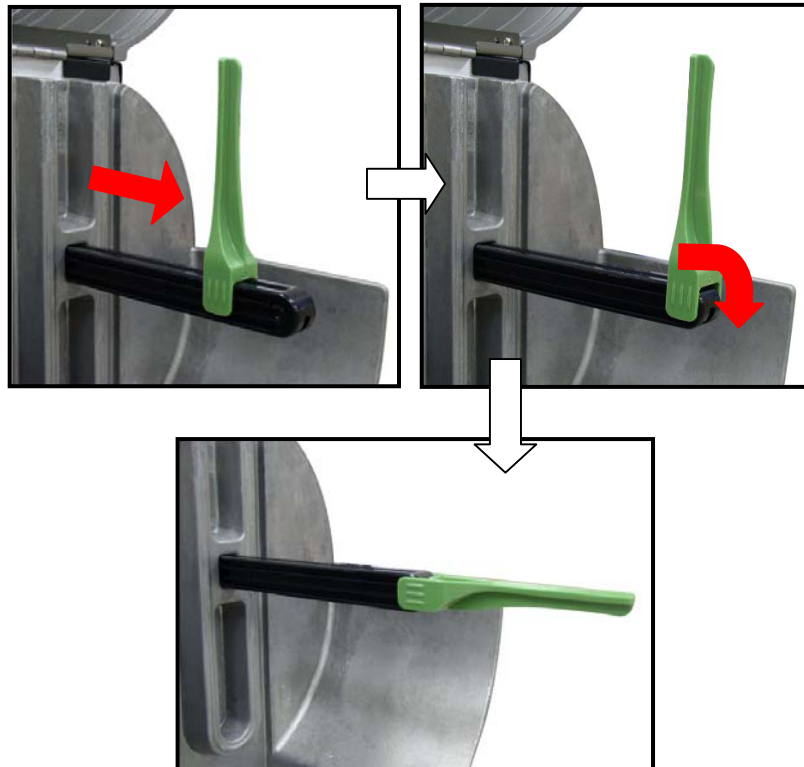

4. Place the roll of media on the label supply spindle. Flip up the label roll guard. Move the label roll guard horizontally to gently fit the width of label roll.

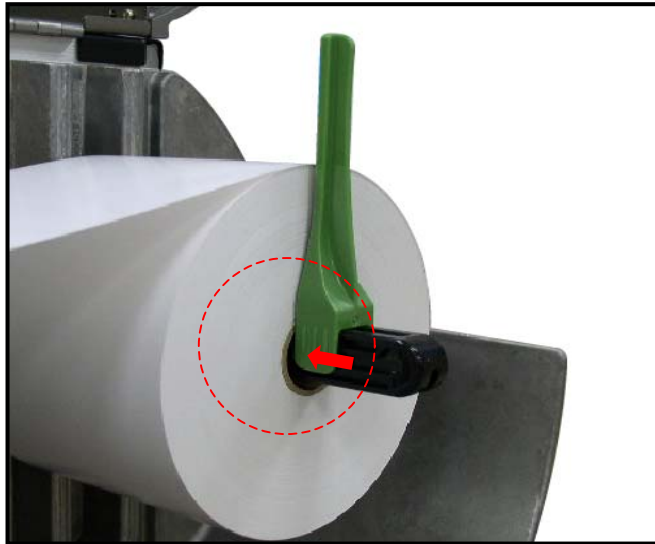

5. Pull label roll leading edge forward through the media guide bar, damper, media sensor and place the label leading edge onto the platen roller.

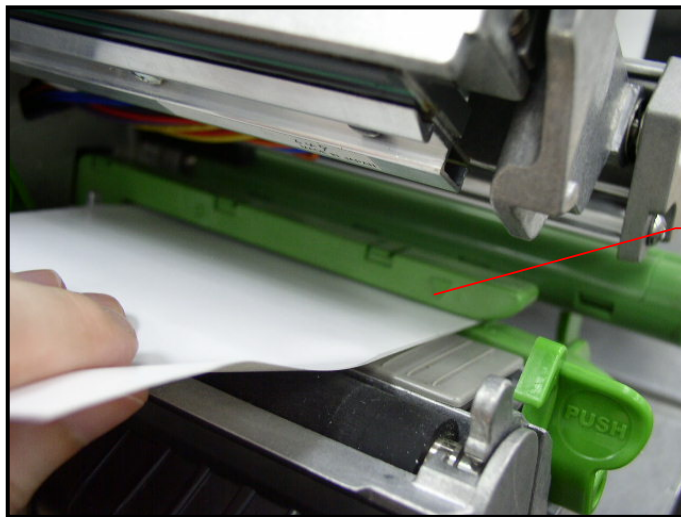

Media sensor

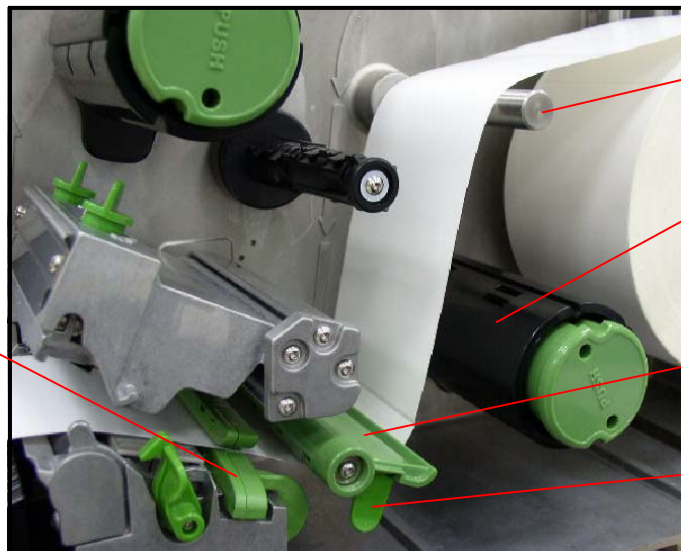

Media sensor

Media guide bar

Internal rewind  
(Option)

Damper

Label guide

6. Adjust the label guide to fit the width of the label.

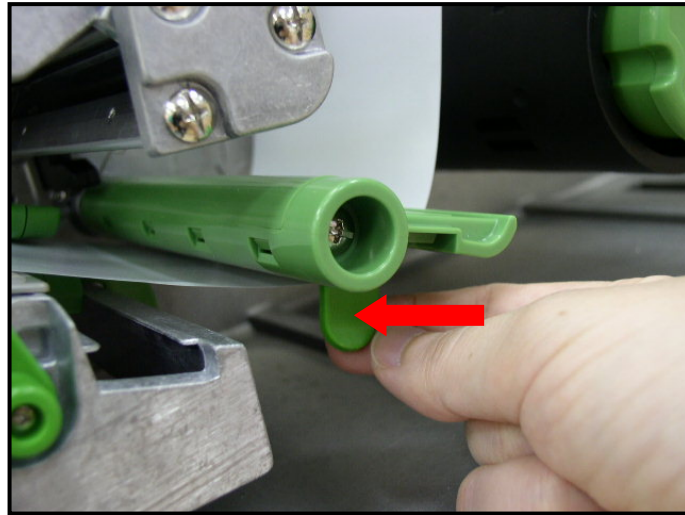

7. Close the print head mechanism making sure the latches are engaged properly.
8. Using the front display panel, set the media sensor type and calibrate the selected sensor. (Please refer to section 3.1.2)

**Note:** Please calibrate the gap/black mark sensor when changing media.

- **Loading path for roll labels**

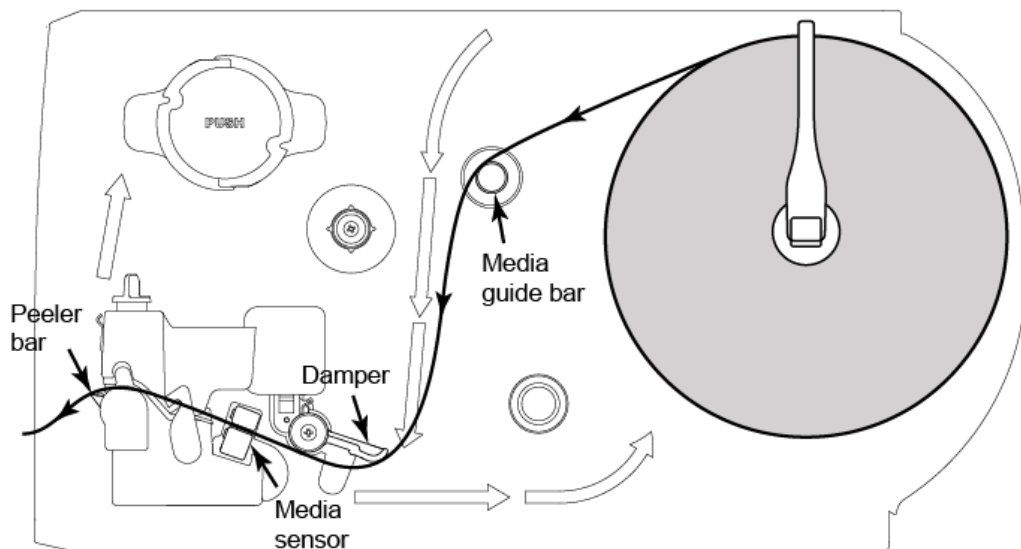

## 2.6.2 Loading Fan-fold Labels

Fan-fold media feeds through either the bottom or rear external label entrance chute.

1. Lift open printer right side cover.
2. Push the print head release lever to open the print head mechanism.



3. Insert the fan-fold media through the bottom or rear external label entrance chute.
4. Pull fan-fold label leading edge forward through the media guide bar, damper media sensor and place the label leading edge onto the platen roller.
5. Adjust the label guide by sliding to fit the paper width.
6. Close the print head mechanism making sure the latches are engaged properly.
7. Set the media sensor type and calibrate the selected sensor. (Please refer to section 3.1.2)

**Note:** Please calibrate the gap/black mark sensor when changing media.

- **Loading path for fan-fold labels**

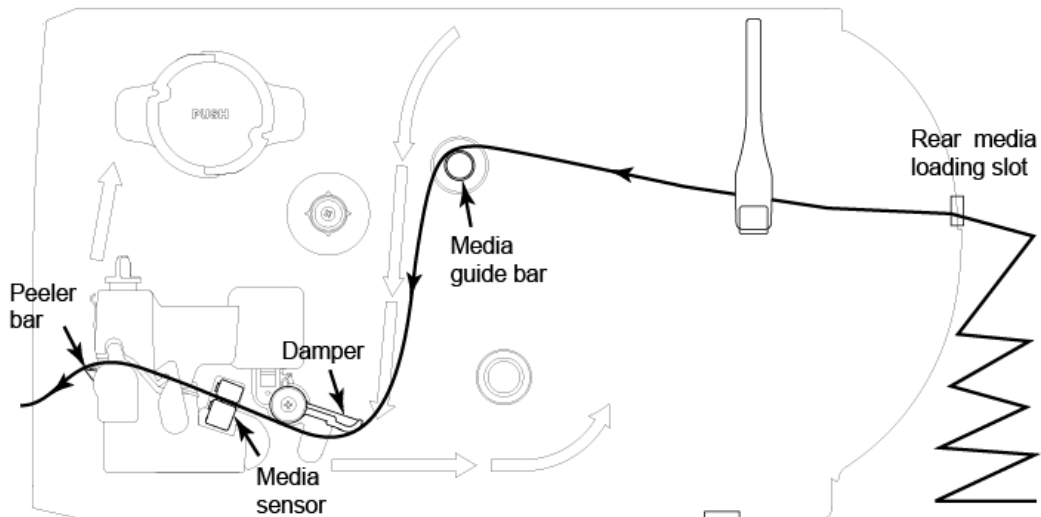

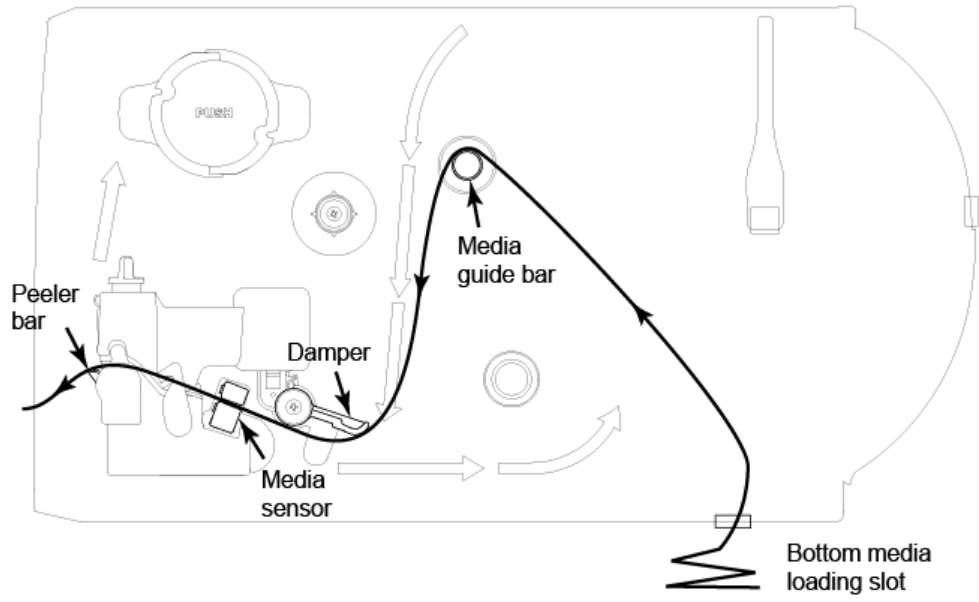

### 2.6.3 Loading Media for Peel-off Mode (Option)

1. Lift open printer right side cover.
2. Push the print head release lever to open the print head mechanism.
3. Move the label roll guard horizontally to the end of label spindle then flip down the label roll guard.
4. Place the roll of media on the label supply spindle. Flip up the label roll guard. Move the label roll guard horizontally to fit the width of label roll.
5. Pull label roll leading edge forward through the media guide bar, damper media sensor and place the label leading edge onto the platen roller.
6. Adjust the label guide to fit the width of the label.
7. Using the front display panel, set the media sensor type and calibrate the selected sensor. (Please refer to section 3.1.2)
8. Then, pull approximately 650mm of label through the front of the printer.
9. Push down the peel-off roller release lever.

Peel-off roller  
release lever



10. Feed the label between peel-off roller and platen roller.



Peel-off roller

11. Wrap the label onto the internal rewriter spindle and wind the spindle counter-clockwise about 3~5 circles until the label is properly stretched.

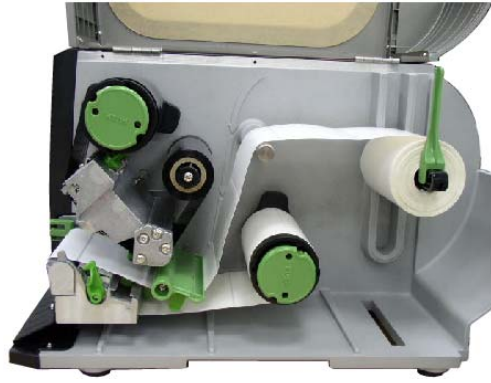

12. Lift up the peel-off roller release lever and close the print head mechanism.

13. Move the peel-off sensor toward the paper exit chute.

Peel-off  
sensor



14. Peeling will automatically start. Press the FEED button to test.

Label

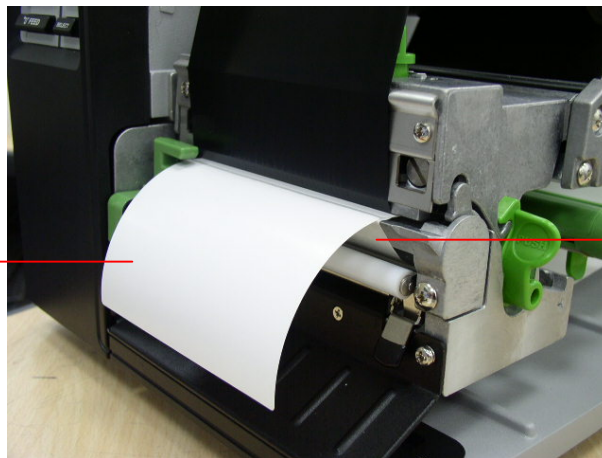

Liner

**Note:**

Please calibrate the gap/black mark sensor when changing media.

### 2.6.4 Remove Liner (Option)

1. Break the liner between peel-off roller and the internal rewinder spindle.



2. Push the liner release button to release the liner on the internal rewinder spindle.



3. Then, slide off the liner from internal rewinder spindle.



## 2.7 Adjustment Knob

### 2.7.1 Print head Pressure Adjustment Knob

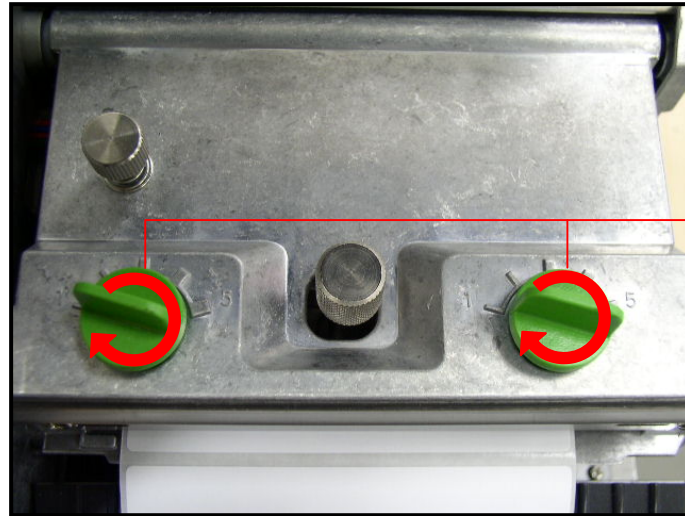

Print head pressure adjustment knobs

The print head pressure adjustment knob has 5 levels of adjustment. Because the printer's paper alignment is to the left side of mechanism, different media widths require different pressure to print correctly. Therefore it may require to adjust the pressure knob to get your best print quality. For example, if the label width is 4", adjust both print head pressure adjustment knobs to the same level. If the label is less than 2" wide, increase the left side print head pressure by rotating the adjustment knob clockwise and decrease the right side pressure by rotating the adjustment knob counter-clockwise to level 1.

### 2.7.2 Print Head Burn Line Adjustment Knob

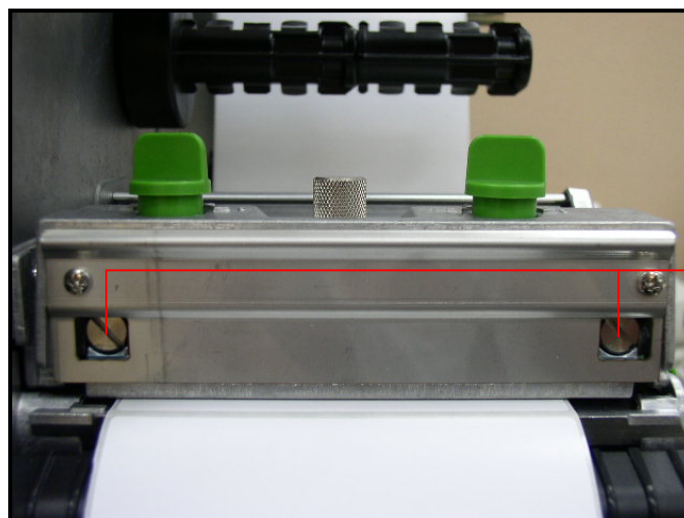

Print head burn line adjustment knobs

The print head burn line adjustment knobs are used to fine tune the print quality for

different thickness of media. Turning the knobs adjusts the print head's burn line forward or backward as it relates to the platen roller.

***Caution: Incorrectly adjusting these knobs can lead to poor print quality and may cause damage to the printer. Proceed with caution.***

The print head burn line default is set for general purpose printing media (plain paper and paper thickness less than 0.20mm). The adjustment knobs default is screwed clockwise to the end of thread.

Poor print quality when using paper thicker than 0.20mm may be due to the print head burn line not being at the optimized position. To improve the print quality, increase the head pressure or adjust the knobs counter-clockwise to move print head burn line toward the paper out direction then print again. Continue to adjust the burn line position and test print as necessary until the printout image is clear.

# 3. Menu Function

## Main Menu Overview

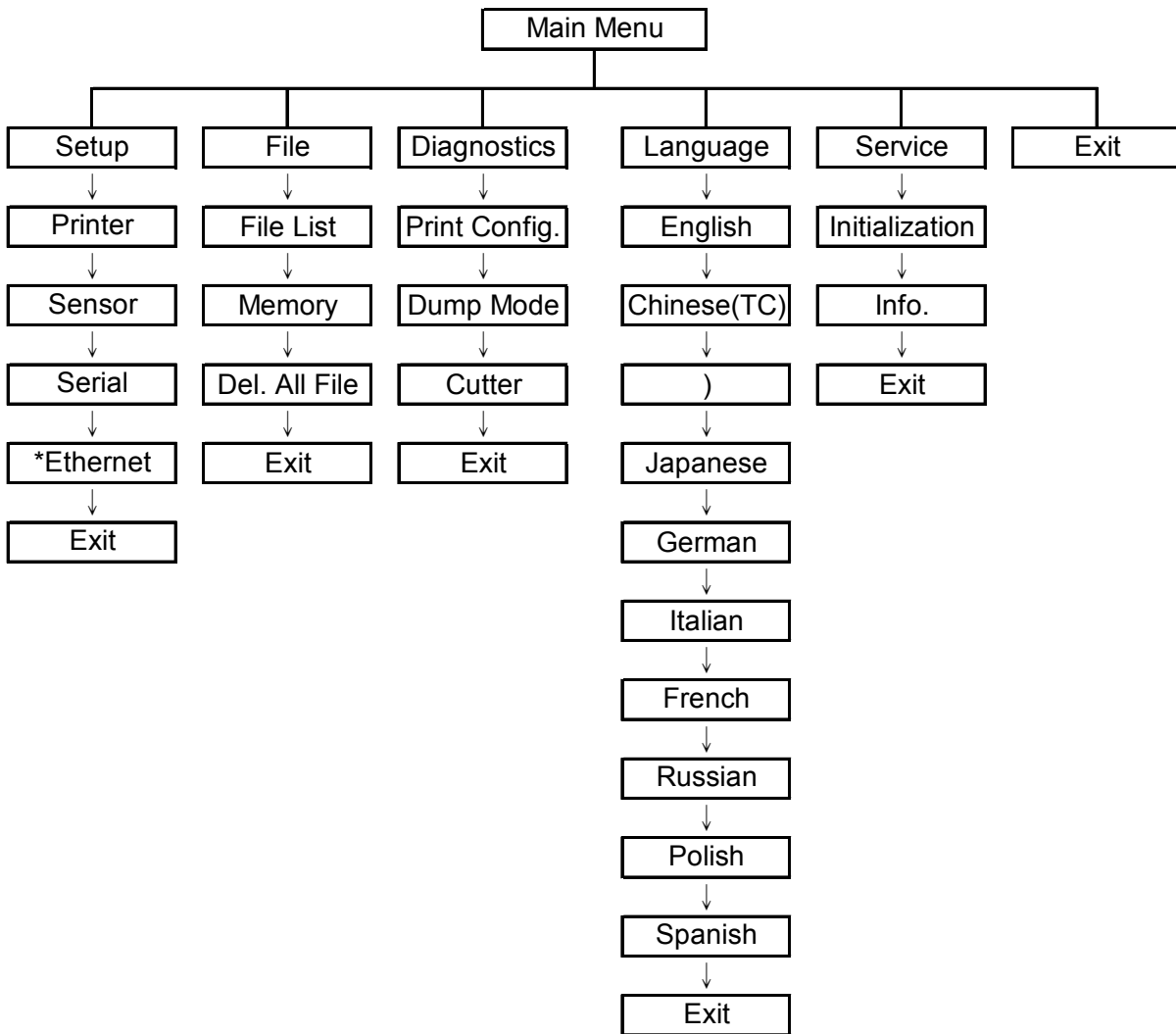

Notice:

\* The Ethernet function is available for TTP-2410M series only and option for TTP-246M Plus series.

\* Ethernet function is available on the LCD display when Ethernet card is installed.

### 3.1 Setup Menu Overview

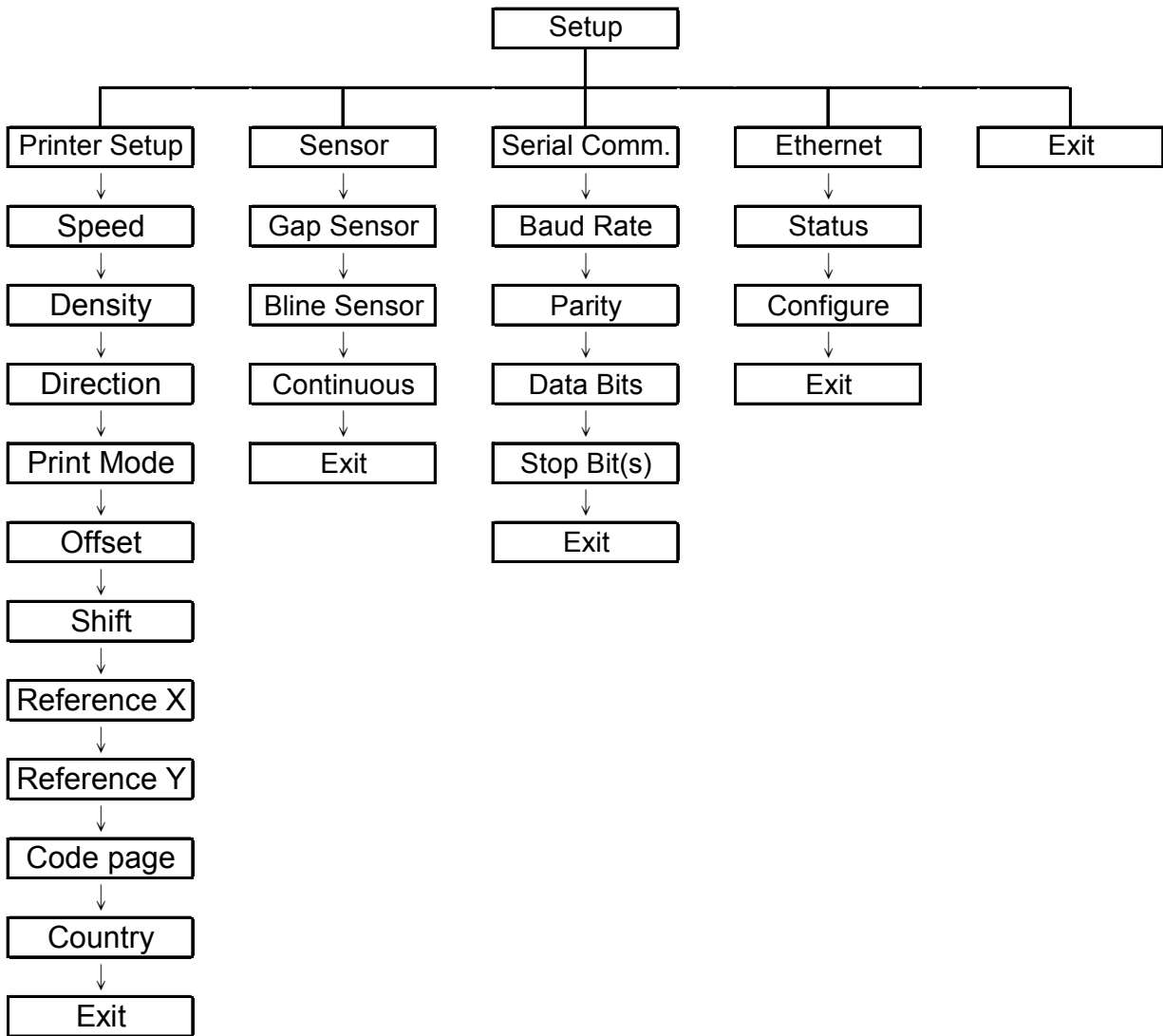

**Notice:**

- \* The Ethernet function is available for TTP-2410M series only and option for TTP-246M Plus series.
- \* Ethernet function is available on the LCD display when Ethernet card is installed.

### 3.1.1 Printer Setup

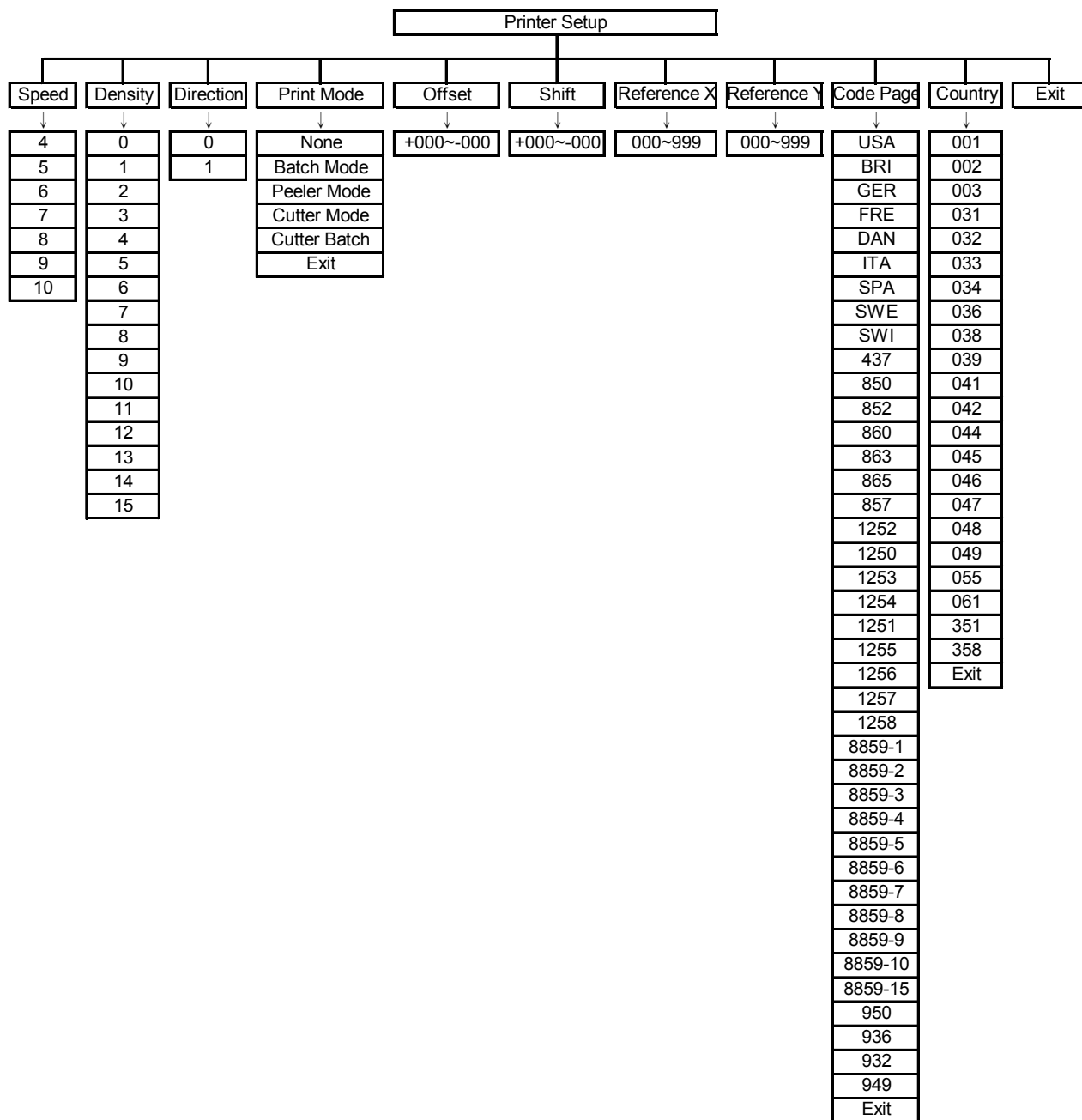

### 3.1.1.1 Speed:

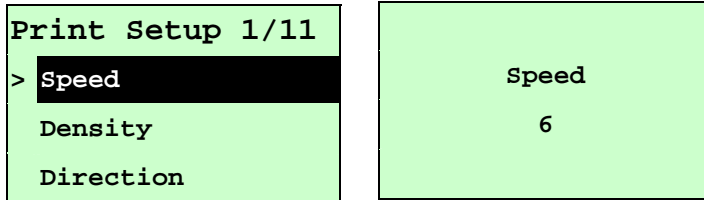

Use this option to setup print speed. The available print speed is between 4~10 ips and each increment/decrement is 1 ips. The default print speed is 6 ips.

Press **UP** ⬆ key to raise the print speed, and press **DOWN** ⬇ key to decrease print speed. Press **SELECT** key to set it into printer. Press **MENU** key to cancel the setting and return to the previous menu.

**Note: If printing from enclosed software/driver, the software/driver will send out the SPEED command, which will overwrite the setting set from the front panel.**

### 3.1.1.2 Density:

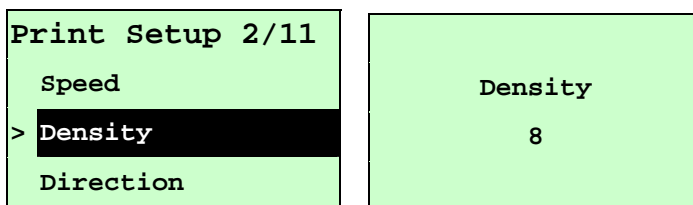

Use this option to setup printing darkness. The available setting is from 0 to 15, and the step is 1. Printer default density is 8. You may need to adjust your density based on selected media.

Press **UP** ⬆ and **DOWN** ⬇ to increase/decrease the printing darkness. Press **SELECT** key to enable the setting. Press **MENU** key to cancel the setting and return to the previous menu.

**Note: If printing from enclosed software/driver, the software/driver will send out the DENSITY command, which will overwrite the setting set from the front panel.**

### 3.1.1.3 Direction:

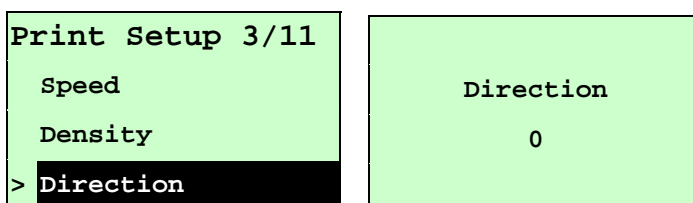

The direction setting value is either 1 or 0. Use this option to setup the printout direction. Printer default printout direction is DIRECTION 0.

Press **UP** ⬆ key to set the direction as 1, and **DOWN** ⬇ to set it as 0, and

**SELECT** key to enable the setting. Press **MENU** key to cancel the setting and return to the previous menu.

The following 2 figures are the printouts of DIRECTION 0 and 1 for your reference.

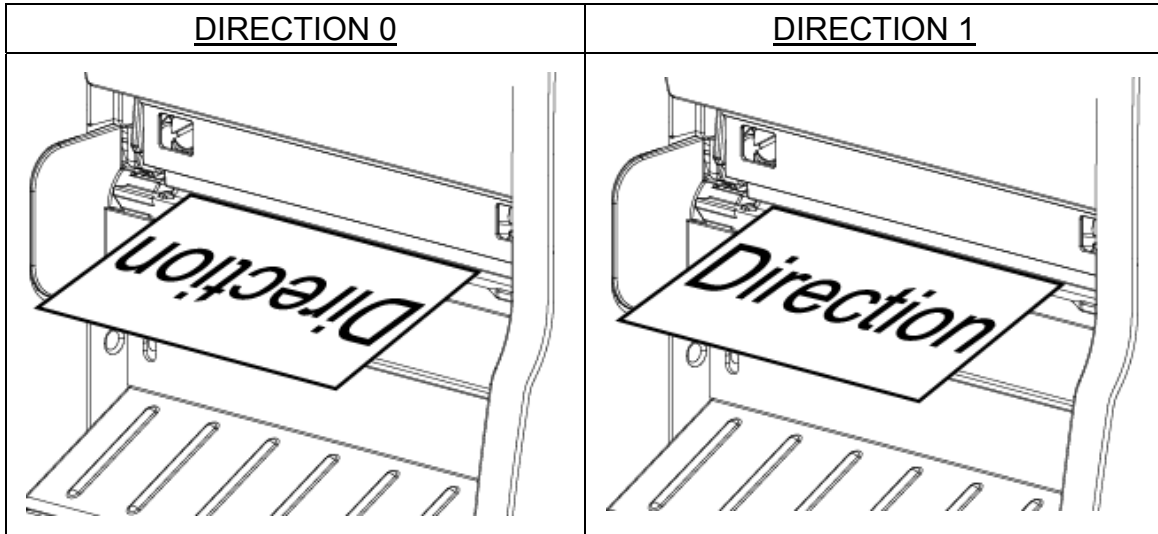

**Note:** If printing from enclosed software/driver, the software/driver will send out the command, which will overwrite the setting set from the front panel.

#### 3.1.1.4 Print Mode: (None/Batch Mode/Peeler Mode/Cutter Mode)

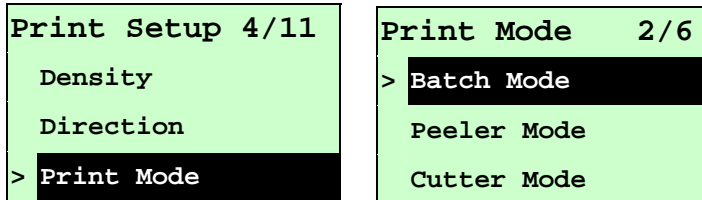

T

This option is used to set the print mode. Printer default setting is Batch Mode. When enter this list, the print mode in the right side of ">" icon is the printer current setting. Press **UP** and **DOWN** to select the different print mode and press **SELECT** button to enable the setting. Press **MENU** key to cancel the setting and return to the previous menu.

| Printer Mode | Description  |
|--------------|--|
| None         | Next label top of form is aligned to the print head burn line location. (Tear Off Mode)                      |
| Batch Mode   | Once image is printed completely, label gap/black mark will be fed to the tear plate location for tear away. |
| Peeler Mode  | Enable the label peel off mode.  |

|              |  |
|--------------|--|
| Cutter Mode  | Enable the label cutter mode.                      |
| Cutter Batch | Cut the label once at the end of the printing job. |

**Note: If printing from enclosed software/driver, the software/driver will send out the command, which will overwrite the setting set from the front panel.**

### 3.1.1.5 Offset:

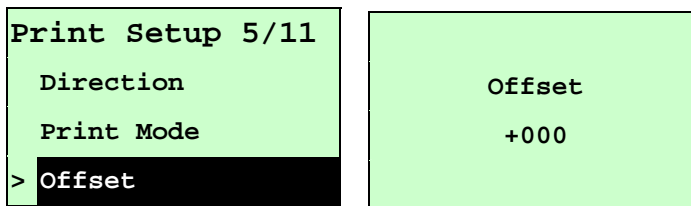

This option is used to fine tune media stop location. Press the **DOWN** Ⓞ button to move the cursor from left digit to right digit, and press the **UP** Ⓞ button to set the value from “+” to “-” or “0” to “9”. Press the **SELECT** button to set the value into printer. Press **≡ MENU** key to cancel the setting and return to the previous menu. The default value is +000.

**Note: If printing from enclosed software/driver, the software/driver will send out the OFFSET command, which will overwrite the setting set from the front panel.**

### 3.1.1.6 Shift:

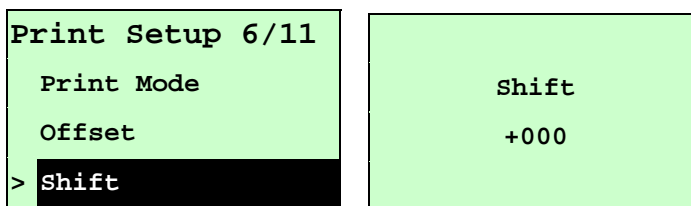

This option is used to fine tune print position. Press the **DOWN** Ⓞ button to move the cursor from left digit to right digit, and press the **UP** Ⓞ button to set the value from “+” to “-” or “0” to “9”. Press the **SELECT** button to set the value into printer. Press **≡ MENU** key to cancel the setting and return to the previous menu. The default value is +000.

**Note: If printing from enclosed software/driver, the software/driver will send out the SHIFT command, which will overwrite the setting set from the front panel.**

### 3.1.1.6 Reference X & Reference Y:

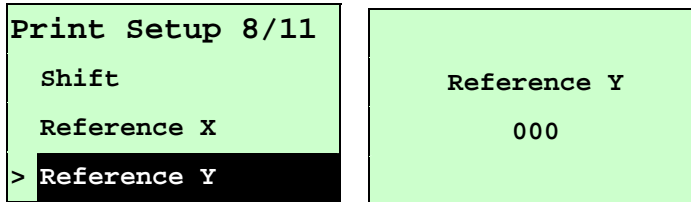

This option is used to set the origin of printer coordinate system horizontally and vertically. Press the **DOWN** ⬇ button to move the cursor from left digit to right digit, and press the **UP** ⬆ button to set the value from “0” to “9”. Press the **SELECT** button to set the value into printer. Press **MENU** key to cancel the setting and return to the previous menu. The default value is 000.

**Note: If printing from enclosed software/driver, the software/driver will send out the REFERENCE command, which will overwrite the setting set from the front panel.**

### 3.1.1.7 Code Page:

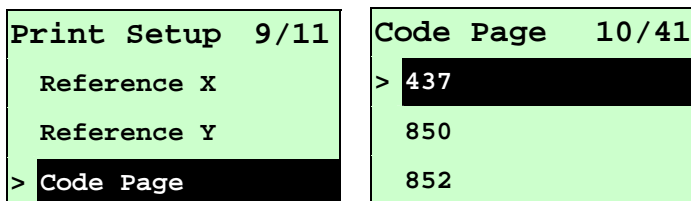

Use this option to set the code page of international character set. For more information about code page, please to refer the programming manual.

When enter the code page list, the code page in the right side of ">" icon is the printer current setting.

Press the **UP** ⬆ and **DOWN** ⬇ to select the code page, and press the **SELECT** button to enable the setting. Press **MENU** key to cancel the setting and return to the previous menu.

**Note: If printing from enclosed software/driver, the software/driver will send out the command, which will overwrite the setting set from the front panel.**

| 7-bit          |                             | 8-bit            |                             |
|----------------|-----------------------------|------------------|-----------------------------|
| code page name | International Character Set | code page number | International Character Set |
| USA            | USA                         | 437              | United States               |
| BRI            | British                     | 850              | Multilingual                |
| GER            | German                      | 852              | Slavic                      |
| FRE            | French                      | 860              | Portuguese                  |
| DAN            | Danish                      | 863              | Canadian/French             |
| ITA            | Italian                     | 865              | Nordic                      |

|     |         |  |  |
|-----|---------|--|--|
| SPA | Spanish |  |  |
| SWE | Swedish |  |  |
| SWI | Swiss   |  |  |

| Windows Code Page (SBCS) |                             | Windows Code Page (DBCS) |                             |
|--------------------------|-----------------------------|--------------------------|-----------------------------|
| code page number         | International Character Set | code page number         | International Character Set |
| 1252                     | Latin 1                     | 950                      | Traditional Chinese Big5    |
| 1250                     | Central Europe              | 936                      | Simplified Chinese GBK      |
| 1253                     | Greek                       | 932                      | Japanese Shift-JIS          |
| 1254                     | Turkish                     | 949                      | Korean                      |
| 1251                     | Cyrillic                    |                          |                             |
| 1255                     | Hebrew                      |                          |                             |
| 1256                     | Arabic                      |                          |                             |
| 1257                     | Baltic                      |                          |                             |
| 1258                     | Vietnam                     |                          |                             |

| ISO Code Page  |                             | ISO Code Page    |                             |
|----------------|-----------------------------|------------------|-----------------------------|
| code page name | International Character Set | code page number | International Character Set |
| 8859-1         | Latin 1                     | 8859-7           | Greek                       |
| 8859-2         | Latin 2                     | 8859-9           | Turkish                     |
| 8859-3         | Latin 3                     | 8859-10          | Latin 6                     |
| 8859-4         | Baltic                      | 8859-15          | Latin 9                     |
| 8859-5         | Cyrillic                    |                  |                             |

### 3.1.1.8 Country:

|                   |              |
|-------------------|--------------|
| Print Setup 10/11 | Country 1/23 |
| Reference Y       | > 001        |
| Code Page         | 002          |
| > Country         | 003          |

Use this option to set the country code for the LCD display. Press the **UP** ⏴ and **DOWN** ⏵ to select the country code, and press the **SELECT** button to set the value into printer. When enter this list, the country code in the right side of ">" icon

is the printer current setting. Press  **MENU** key to cancel the setting and return to the previous menu.

| <b>Code</b> | <b>Country</b>          | <b>Code</b> | <b>Country</b>  | <b>Code</b> | <b>Country</b> | <b>Code</b> | <b>Country</b>          |
|-------------|-------------------------|-------------|-----------------|-------------|----------------|-------------|-------------------------|
| 001         | USA                     | 034         | Spanish (Spain) | 044         | United Kingdom | 055         | Brazil                  |
| 002         | Canadian-French         | 036         | Hungarian       | 045         | Danish         | 061         | English (International) |
| 003         | Spanish (Latin America) | 038         | Yugoslavian     | 046         | Swedish        | 351         | Portuguese              |
| 031         | Dutch                   | 039         | Italian         | 047         | Norwegian      | 358         | Finnish                 |
| 032         | Belgian                 | 041         | Switzerland     | 048         | Polish         |             |                         |
| 033         | French (France)         | 042         | Slovak          | 049         | German         |             |                         |

### 3.1.2 Sensor

This option is used to set the media sensor type and calibrate the selected sensor. We recommend to calibrate the sensor before printing when changing the media.

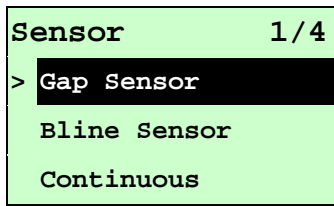

When you enter this option, the sensor type in the right side of ">" icon is the printer current setting. Press the **UP** ⬆ and **DOWN** ⬇ to select the sensor type, and press the **SELECT** button to enter sensor calibration mode. Press **MENU** key to cancel the setting and return to the previous menu.

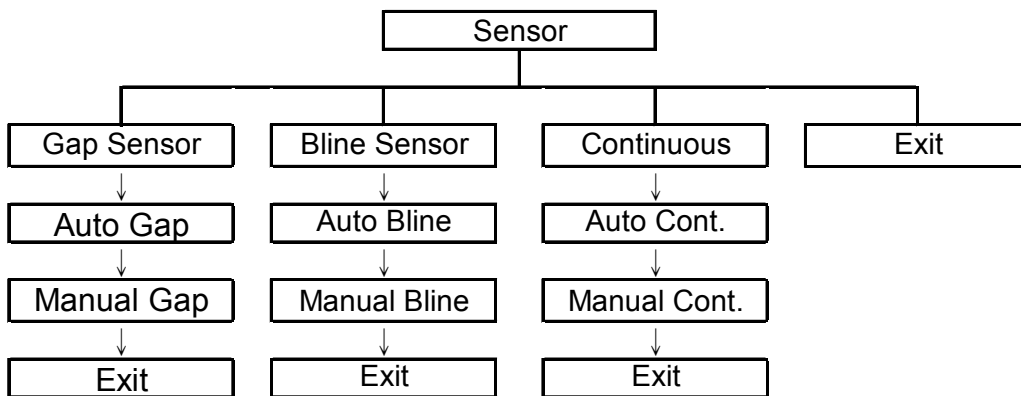

#### 3.1.2.1 Gap Sensor Calibration

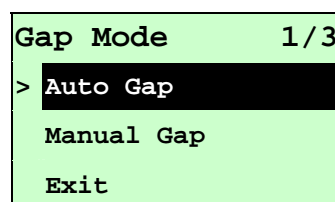
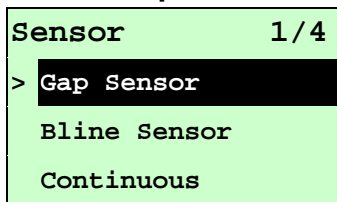

Press the **UP** ⬆ and **DOWN** ⬇ buttons to scroll the cursor to the sensor type and press the **SELECT** button to enter the sensor calibration mode.

**Note:** *If printing from enclosed software/driver, the software/driver will send out the GAP or BLINE command, which will overwrite the sensor type setting set from the front panel.*

##### 3.1.2.1.1 Auto Gap Sensor Calibration

When enter the [Auto Gap] option, you will see following message, and

printer will feed 2 to 3 labels to calibrate the sensor sensitivity. When calibration is completed, the LCD screen will return to the previous menu.



### 3.1.2.1.2 Manual Gap Sensor Calibration

In case “Auto Gap” sensor calibration cannot apply to the media, please use “Manual Gap” function to calibrate the gap sensor manually. This function can be used to fine tune the sensor sensitivity.

When enter [Manual Gap] option, you will see following message.

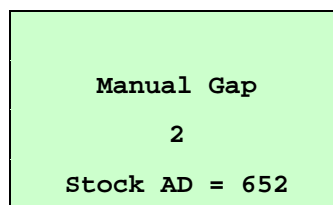
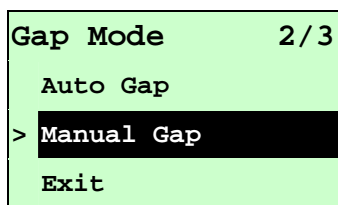

Press the **UP** ⬆ and **DOWN** ⬇ buttons, you will see there are 8 different sensitivity ranges (0~7) of sensor setting. Disengage the print head mechanism. Remove one label from the liner and place the liner under the gap sensor. You can read the “Stock AD” value for the liner. Move the media to liner with label and you can read another “Stock AD” value. If the difference between the two readings is larger than 250 then sensor can register label top of form properly. If the current sensitivity range difference is not much, you can change to another sensitivity range setting by pressing the **UP** ⬆ and **DOWN** ⬇ buttons, and press the **SELECT** to set the value to printer or press **MENU** key to cancel the setting and return to the previous menu.

### 3.1.2.2 Black Sensor Calibration

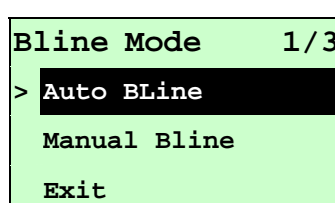
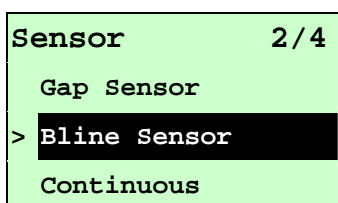

Press the **UP** ⬆ and **DOWN** ⬇ buttons to scroll the cursor to the sensor type. Press

the **SELECT** button to enter the black mark sensor calibration mode.

### 3.1.2.2.1 Auto Black Mark Sensor Calibration

When enter the [Auto Bline] option, you will see following message and printer will feed 2 to 3 labels to calibrate the black mark sensor sensitivity. When calibration process is completed, the LCD screen will return to the previous menu.

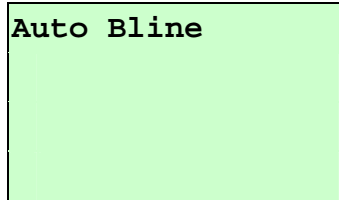

### 3.1.2.2.2 Manual Black Mark Sensor Calibration

In case “Auto Bline” sensor calibration cannot calibrate the sensor properly, you will need to calibrate the sensor manually. This function is used to fine tune black mark sensor sensitivity. When enter the [Manual Bline] option, you will see following message.

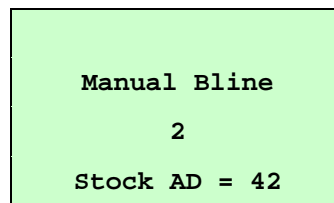
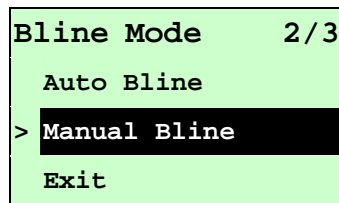

There are 4 different ranges (0~3) of sensor sensitivity. Disengage the print head mechanism. Place the black mark under the black mark sensor. You can read the “Stock AD” value from the LCD for the black mark. Move the label to the area other than the black mark and check the “Stock AD” value again. If the readings difference between black stripe and other areas are larger than 250, then sensor is able to register at the media top of form properly. If the “Stock AD” value difference are less than 250, please press the **UP** ⬆ and **DOWN** ⬇ buttons to change to other sensitivity range, and press the **SELECT** to set the value to printer or press **MENU** key to cancel the setting and return to the previous menu.

**Note: If there are texts or logos at the sensor detection path, they will affect the sensor sensitivity and printer may not able to register the top of form properly. For this case, please move the sensor to the location where there is no texts or logos on the sensor detection path.**

### 3.1.2.3 Continuous Media Sensor Calibration

When enter the [Continuous] option, you will see following messages.

```
Sensor      3/4
  Gap Sensor
  Bline Sensor
> Continuous
```

```
Cont. Mode  1/3
> Auto Cont.
  Manual Cont.
  Exit
```

Press the **UP** ⬆ and **DOWN** ⬇ buttons to select the sensor calibration mode, and press the **SELECT** button to detect sensor strength

### 3.1.2.2.1 Auto Cont.:

When enter the [Auto Cont.] option, you will see following message and printer will not feed labels to calibrate the sensor sensitivity. When calibration process is completed, the LCD screen will return to the previous menu.

```
Auto Cont.
```

### 3.1.2.1.2 Manual Sensor Calibration for The Continuous Media

In case Auto Continuous sensor calibration cannot apply to the media, please calibrate the media manually with “Manual Cont.” option. This function can be used to fine tune the sensor sensitivity. When enter [Manual Cont.] option, you will see following messages.

```
Cont. Mode  2/3
  Auto Cont.
> Manual Cont.
  Exit
```

```
Manual Cont.
      2
Stock AD = 42
```

There are 8 different ranges (0~7) of sensor sensitivity. Please disengage the print head mechanism. Place the media under the gap sensor and check the “Stock AD” value. Remove the media from the gap sensor and check the “Stock AD” value again. If difference of the two readings are larger than 250 then printer can detect the media properly. If the readings difference is less than 250 then press the **UP** ⬆ and **DOWN** ⬇ buttons to change the sensor sensitivity to different range and check the readings difference again. Press

the **SELECT** key to set the value to printer or press **MENU** key to cancel the setting and return to the previous menu.

### 3.1.3 Serial Comm.

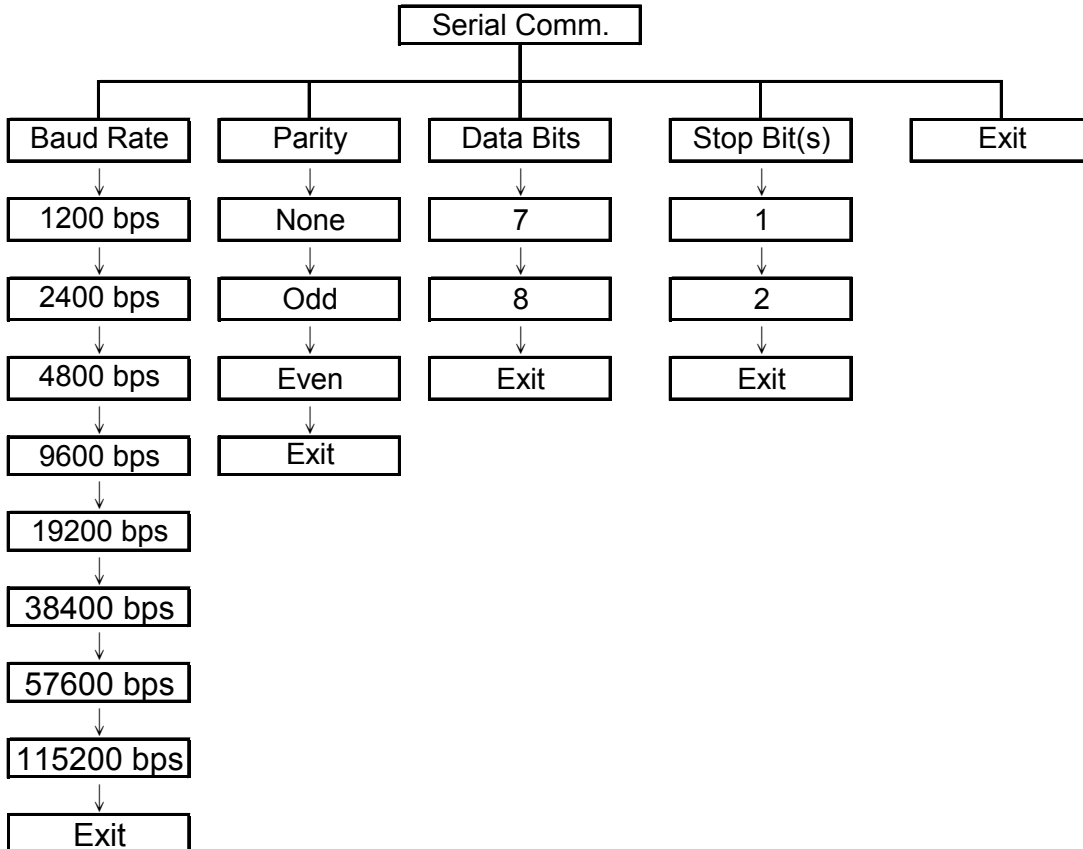

#### 3.1.3.1 Baud Rate

```

Serial Comm. 1/5
> Baud Rate
  Parity
  Data Bits
  
```

```

Baud Rate 4/9
> 9600 bps
  19200 bps
  38400 bps
  
```

This option is used to set the RS-232 baud rate. The default setting is 9600 bps. Press **UP** and **DOWN** buttons to select the different baud rate and press **SELECT** button to set the value into printer. When you enter this list, the baud rate value in the right side of ">" icon is the current setting in the printer. Press **MENU** key to cancel the setting and return to the previous menu.

### 3.1.3.2 Parity

```
Serial Comm. 2/5
  Baud Rate
> Parity
  Data Bits
```

```
Parity 1/4
> None
  Odd
  Even
```

This option is used to set the RS-232 parity. The default setting is “None”. Press **UP** ⤴ and **DOWN** ⤵ buttons to select the different parity and press **SELECT** button to set the value into printer. When you enter this list, the parity in the right side of ">" is the printer current setting. Press **MENU** key to cancel the setting and return to the previous menu.

### 3.1.3.3 Data Bits:

```
Serial Comm. 3/5
  Baud Rate
  Parity
> Data Bits
```

```
Data Bits 2/3
  7
> 8
  Exit
```

This option is used to set the RS-232 Data Bits. The default setting is “8” data bits. Press **UP** ⤴ and **DOWN** ⤵ buttons to select the different Data Bits and press **SELECT** button to set the value into printer. When you enter this list, the Data Bits in the right side of ">" icon is the printer current setting. Press **MENU** key to cancel the setting and return to the previous menu.

### 3.1.3.4 Stop Bit(s):



```
Serial Comm. 4/5
  Parity
  Data Bits
> Stop Bit(s)
```

```
Stop Bit(s) 1/3
> 1
  2
  Exit
```

This option is used to set the RS-232 Stop Bits. The default setting is “1” stop bit. Press **UP** ⤴ and **DOWN** ⤵ buttons to select the different Stop Bits and press **SELECT** button to set the value into printer. When you enter this list, the option in the right side of ">" icon is the printer current setting. Press **MENU** key to cancel the setting and return to the previous menu.

### 3.1.4 Ethernet

Use this menu to configure internal Ethernet configuration check the printer's Ethernet module status, and reset the Ethernet module. This function is available on the LCD display when Ethernet card is installed.

Press **UP**  and **DOWN**  buttons to select the different options and press **SELECT** button to enter the option. Press  **MENU** key to cancel the setting and return to the previous menu.

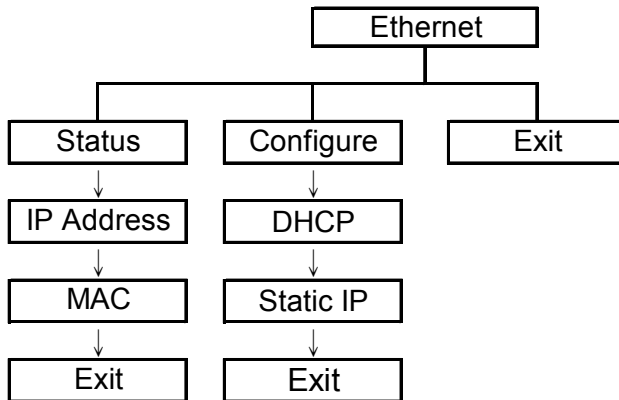

#### Note:

This function is available for TTP-2410M series only and option for TTP-246M Plus series.

#### 3.1.4.1 Status: (IP Address / MAC)

Use this menu to check the Ethernet setting status.

##### 3.1.4.1.1 IP Address

```
Ethernet 1/3
> Status
  Configure
  Exit
```

```
Status 1/3
> IP Address
  MAC
  Exit
```

```
IP Address
0.0.0.0
Subnet Mask
0.0.0.0
Gateway
0.0.0.0
```

The IP address information will be shown on the LCD display. Please press **SELECT** or  **MENU** button to return to the previous menu.

### 3.1.4.1.2 MAC

```
Ethernet      1/3
> Status
Configure
Exit
```

```
Status      2/3
IP Address
> MAC
Exit
```

```
MAC Address
00-1B-82
FF-20-E4
```

The MAC address information will be shown on the LCD display. Please press **SELECT** or **MENU** button to return to the previous menu.

### 3.1.4.2 Configure: (DHCP / Static IP)

Use this menu to set the printer's DHCP and Static IP.

#### 3.1.4.2.1 DHCP

```
Ethernet      2/4
Status
> Configure
Reset
```

```
Configure     1/3
> DHCP
Static IP
Exit
```

Press **UP** and **DOWN** buttons to select the DHCP function and press **SELECT** to enter. Press **MENU** key to cancel the setting and return to the previous menu.

```
                DHCP
SELECT:          YES
MENU:           NO
```

Press **SELECT** button the printer will set DHCP and restart to reset the setting. Press **MENU** button to return to the previous menu.

### 3.1.4.2.2 Static IP

Use this menu to set the printer's IP address, subnet mask and gateway.

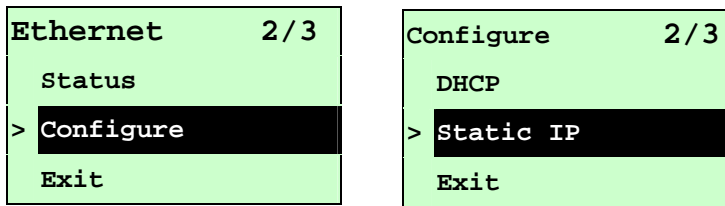

Press **UP** and **DOWN** buttons to select the different options and press **SELECT** button to enter the option. Press **MENU** key to cancel the setting and return to the previous menu.

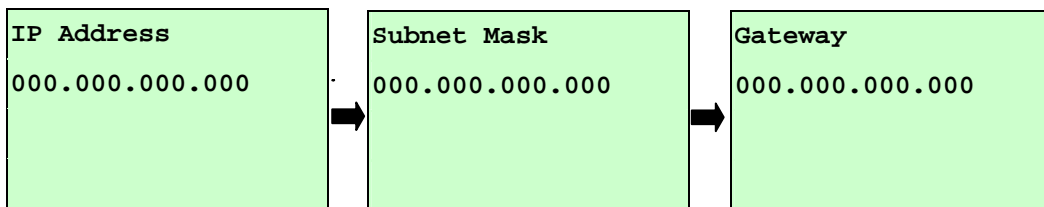

Press **DOWN** button to move the cursor from left to right digits and press the **UP** button to scroll the value from "0" to "9". Press **SELECT** button to next setting.

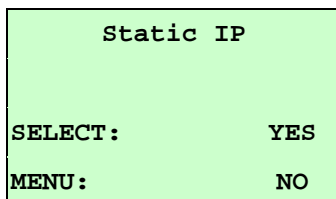

Press the **SELECT** button printer will restart to reset the Ethernet module setting. Press **MENU** key to cancel the setting.

## 3.2 File Manager

This feature is used to check the printer available memory and file list.

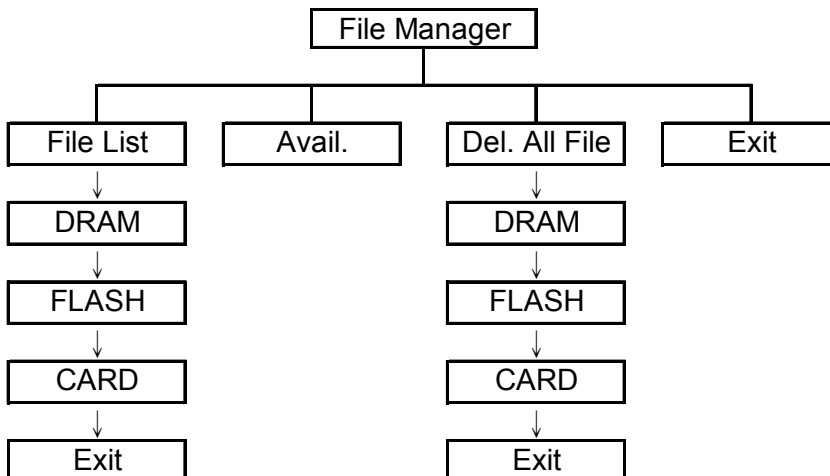

### 3.2.1 File List

Use this menu to show the files that are saved in printer DRAM/flash memory.

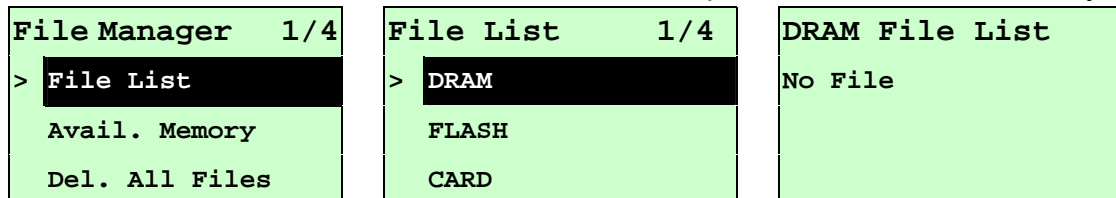

### 3.2.2 Avail. Memory

Use this menu to show available memory space.

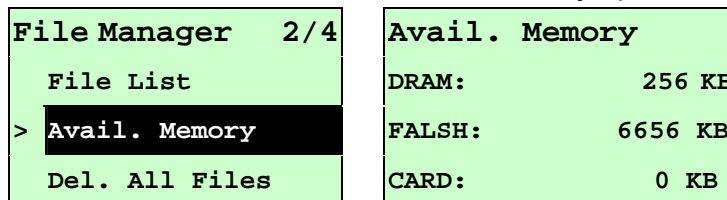

### 3.2.3 Del. All Files

Use this menu to delete all files. Press **SELECT** button to delete all files in the device.

Press **MENU** to cancel deleting files and go back to previous menu.

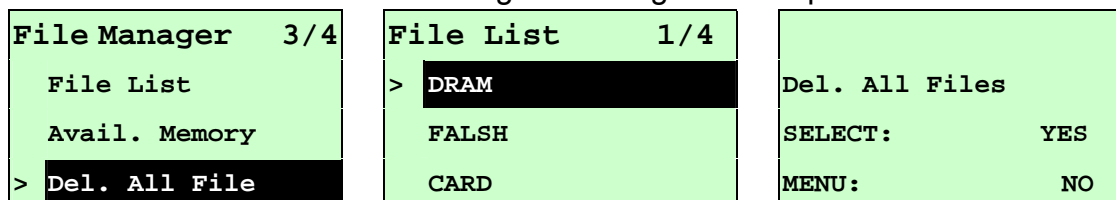

### 3.3 Diagnostics

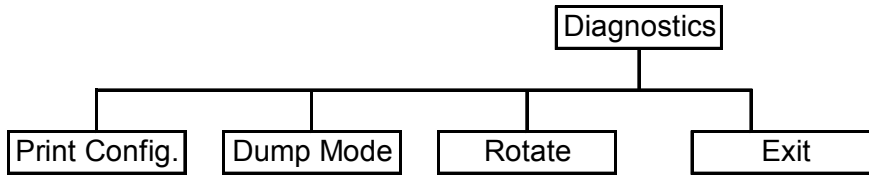

#### 3.3.1 Print Config.

This feature is used to print current printer configuration to the label. On the sconfiguration printout, there is a print head test pattern, which is useful for checking if there is any dot damage on the print head heater element.

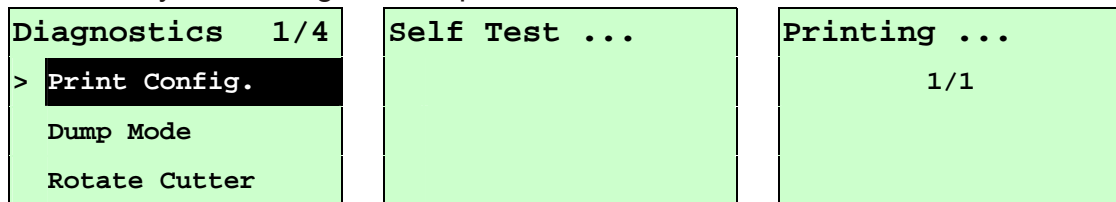

|  |   |
|--|---|
| <pre> <b>PRINTER INFO.</b> [Print head test pattern] TTP2410M Version: X.XX EZ MILAGE(m): 2 CHECKSUM: 05BB8D70 SERIAL PORT: 9600,N,8,1 CODE PAGE: 437 COUNTRY CODE: 001 SPEED: 6 INCH DENSITY: 12 SIZE: 4.00 , 6.00 GAP: 0.00 , 0.00 TRANSPARENCE: 2 HOST NAME: admin MAC ADDRESS: 00-1B-82-FF-02-63 DHCP ENABLED: YES IP ADDRESS: 0.0.0.0 SUBNET MASK: 0.0.0.0 DEFAULT GATEWAY: 0.0.0.0 ***** FILE LIST: DRAM FILE:          0 FILE(S) FLASH FILE:         0 FILE(S) EXT.FLASH FILE:     0 FILE(S) PHYSICAL DRAM:      32768 KBYTES AVAILABLE DRAM:     256 KBYTES FREE PHYSICAL FLASH:     8192 KBYTES AVAILABLE FLASH:    6656 KBYTES FREE PHYSICAL CARD:      976 MBYTES END OF FILE LIST *****           </pre> | <p>Print head test pattern</p> <p>Printer model name &amp; Main board firmware version</p> <p>Printed mileage</p> <p>Main board firmware checksum</p> <p>Serial port setting</p> <p>Code page</p> <p>Country code</p> <p>Print speed</p> <p>Print darkness</p> <p>Label size (width, height)</p> <p>Gap size (vertical gap, offset)</p> <p>Sensor sensitivity</p><br><p>File management information</p> |
|--|---|

### 3.3.2 Dump Mode

Captures the data from the communications port and prints out the data received by printer. In the dump mode, all characters will be printed in 2 columns as following. The left side characters are received from your system and right side data are the corresponding hexadecimal value of the characters. It allows users or engineers to verify and debug the program.

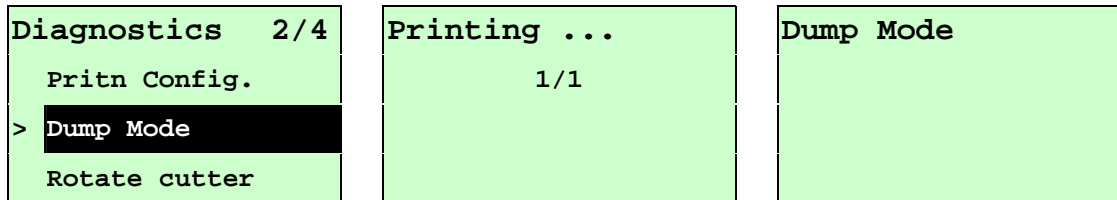

**Note:**

- 1. Dump mode requires 4" wide paper width.**
- 2. Turn off / on the power to resume printer for normal printing.**
- 3. Press FEED button to back to the previous menu.**

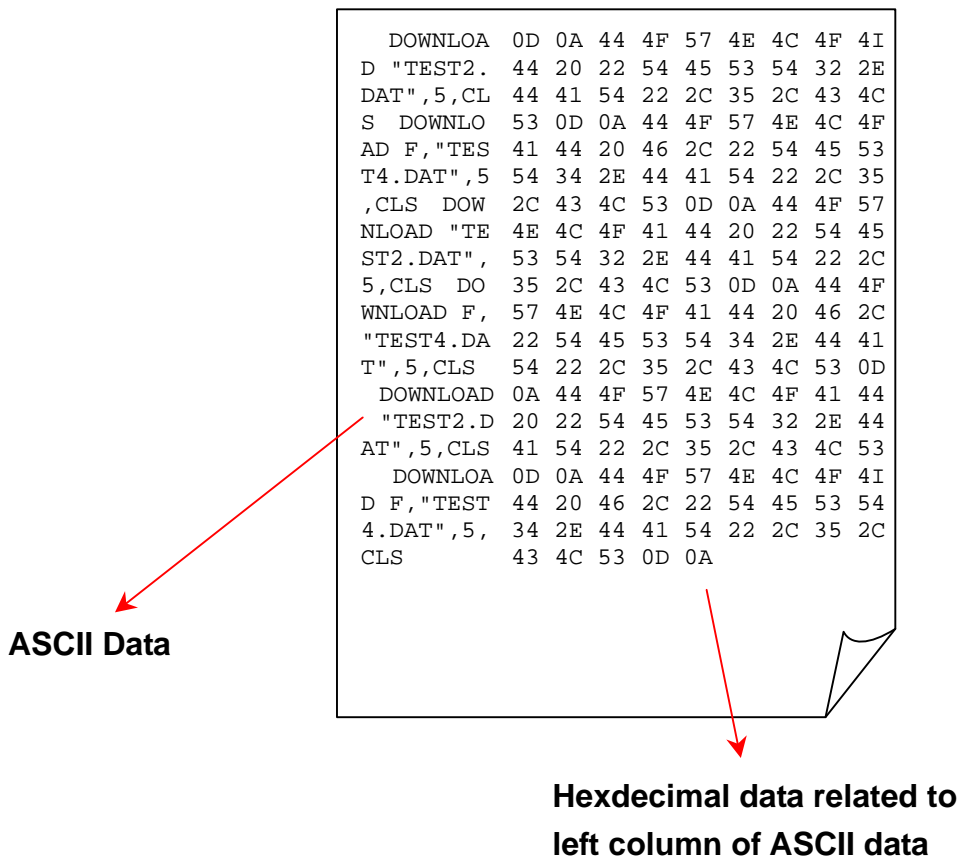

### 3.3.3 Rotate Cutter

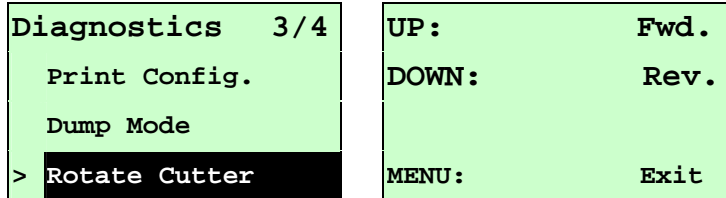

In case paper is jammed in the cutter, this feature can rotate the cutter blade forward or reverse direction, which is helpful to remove the jammed paper easily from the cutter.

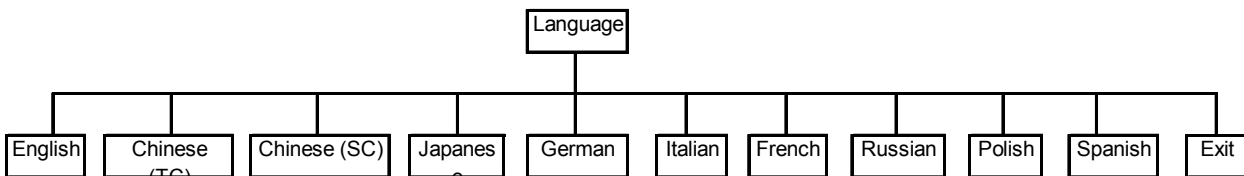

### 3.4 Language



This option is used to setup the language on LCD display.

Press **UP**  and **DOWN**  buttons to scroll the cursor to desire language and press **SELECT** button to select this option. Press  **MENU** key to cancel the setting and return to the previous menu. The default language setting is English.

## 3.5 Service

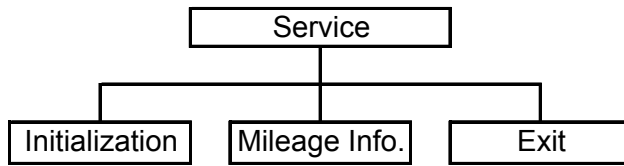

This feature is used to restore printer settings to defaults and display printer mileage information.

### 3.5.1 Initialization

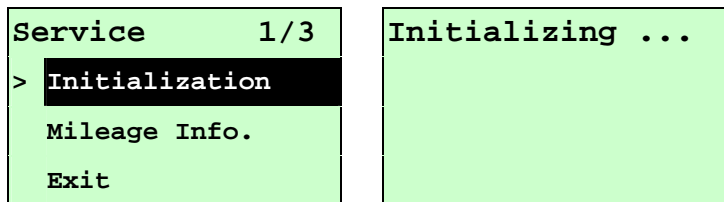

The printer settings are restored to defaults as below once printer is initialized.

**Note :**

***When printer initialization is done, please calibrate the gap or black mark sensor before printing.***

| Parameter              | Default setting                                 |
|------------------------|---|
| Speed                  | 6 IPS (152 mm/sec)                              |
| Density                | 8   |
| Label Width            | 4.00"(101.6mm)                                  |
| Label Height           | 2.50"(63.4mm)                                   |
| Sensor Type            | Gap sensor                                      |
| Gap Setting            | 0.12"(3.0mm)                                    |
| Print Direction        | 0   |
| Reference Point        | 0,0(upper left corner)                          |
| Offset                 | 0   |
| Tear Mode              | On  |
| Peel off Mode          | Off   |
| Serial Port Settings   | 9600 bps, none parity, 8 data bits, 1 stop bit  |
| Code Page              | 437   |
| Country Code           | 001   |
| Clear Flash Memory     | No  |
| Shift                  | 0   |
| Gap sensor sensitivity | 2 (Will be reset. Need to re-calibrate the gap) |

|                                 |   |
|---------------------------------|---|
| <b>Blinc sensor sensitivity</b> | 2 (Will be reset. Need to re-calibrate the gap) |
| <b>Language</b>                 | English   |

### 3.5.2 Mileage Info.

Use this option to check the printed mileage (displayed in meter).

|                        |                       |
|------------------------|-----------------------|
| <b>Service</b> 1/3     | <b>Mileage: (m)</b>   |
| Initialization         | 4016                  |
| > <b>Mileage Info.</b> | <b>Labels: (pcs.)</b> |
| Exit                   | 51698                 |

## 4. Troubleshooting

The following guide lists the most common problems that may be encountered when operating this bar code printer. If the printer still does not function after all suggested solutions have been invoked, please contact the Customer Service Department of your purchased reseller or distributor for assistance.

| <b>Problem</b>                             | <b>Possible Cause</b>  | <b>Recovery Procedure</b>  |
|--|--|--|
| <b>Power indicator does not illuminate</b> | The power cord is not properly connected.                                  | Check whether the power cord is well connected between printer and outlet.           |
|  | Power switch is not turned on.   | Turn on power switch.  |
| <b>Carriage open</b>                       | The printer carriage is open.  | Please engage the print mechanism.   |
| <b>Not Printing</b>                        | Check if interface cable is well connected to the interface connector.     | Re-connect cable to interface.   |
|  | The serial port cable pin configuration is not pin to pin assignment.      | Please replace the cable with pin to pin assignment.                                 |
|  | The serial port setting is not consistent between host and printer.        | Please reset the serial port setting.  |
|  | The port specified in the Windows driver is not correct.                   | Select the correct printer port in the driver  |
|  | The Ethernet IP, subnet mask, gateway is not configured properly           | Configure the IP, subnet mask, gateway.  |
| <b>No Ribbon</b>                           | Running out of ribbon  | Supply a new ribbon roll   |
|  | The ribbon is installed incorrectly.                                       | Please refer to the steps in user's manual to reinstall the ribbon.                  |
| <b>No Paper</b>                            | Run out of label.  | Supply a new label roll.   |
|  | Gap/black mark sensor is not aligned properly to the media                 | Align the triangle on the sensor support to the media gap/notch/black mark properly. |
|  | The label is installed incorrectly.  | Please refer to the steps in user's manual to reinstall the label roll.              |
|  | Gap/black mark sensor sensitivity is too high or sensor is not calibrated. | Calibrate the gap/black mark sensor.   |

|   |  |  |
|---|--|--|
| <b>Paper Jam</b>                            | Gap/black mark sensor sensitivity is not set properly (sensor sensitivity is not enough) | Calibrate the gap/black mark sensor  |
|   | Make sure label size is set properly.  | Set label size exactly as installed paper in the labeling software or program.                     |
|   | Labels may be stuck inside the printer mechanism near the sensor area.                   | Remove the stuck label.  |
|   | The serial port cable pin configuration is not correct.                                  | Please replace the null modem cable  |
| <b>Poor Print Quality</b>                   | Check if supply is loaded correctly  | Reload the supply  |
|   | Ribbon and media are incompatible.   | Change the ribbon or label combination   |
|   | Check if dust or adhesives are accumulated on the print head.                            | Clean the print head   |
|   | Check if print density is set properly.  | Adjust the print density and print speed.  |
|   | Check print head test pattern if head element is damaged                                 | Run printer self-test and check the print head test pattern if there is dot missing in the pattern |
|   | The pressure of print head is not set properly   | Adjust the print head pressure adjustment knob.  |
|   | Printed thick tag  | Adjust the print head pressure and print head burn line position                                   |
| <b>Memory full ( FLASH / DRAM/SD card )</b> | The space of FLASH/DRAM is full.   | Delete unused files in the FLASH/DRAM/SD card.   |

## 5. Maintenance

This session presents the clean tools and methods to maintain your printer.

1. Please use one of following material to clean the printer.

- Cotton swab
- Lint-free cloth
- Vacuum / Blower brush
- 100% ethanol

2. The cleaning process is described as following

| Printer Part             | Method   | Interval   |
|--------------------------|--|--|
| <b>Print Head</b>        | 1. Always turn off the printer before cleaning the print head.<br>2. Allow the print head to cool for a minimum of one minute.<br>3. Use a cotton swab and 100% ethanol to clean the print head surface. | Clean the print head when changing a new label roll    |
| <b>Platen Roller</b>     | 1. Turn the power off.<br>2. Rotate the platen roller and wipe it thoroughly with 100% ethanol and a cotton swab, or lint-free cloth.  | Clean the platen roller when changing a new label roll |
| <b>Tear Bar/Peel Bar</b> | Use the lint-free cloth with 100% ethanol to wipe it.  | As needed  |
| <b>Sensor</b>            | Compressed air or vacuum   | Monthly  |
| <b>Exterior</b>          | Wipe it with water-dampened cloth  | As needed  |
| <b>Interior</b>          | Brush or vacuum  | As needed  |

### Note:

- Do not touch printer head by hand. If you touch it careless, please use ethanol to clean it.
- Please use 100% Ethenol. DO NOT use medical alcohol, which may damage the printer head.
- Regularly clean the print head and supply sensors once change a new ribbon to keep printer performance and extend printer life.

## Revise History

| Date       | Content  | Editor  |
|------------|--|---------|
| 2007/10/24 | Update Ethernet section. (Section 3.1.4)                             | Camille |
| 2007/10/31 | Add SD card specification. (Section 2.2.3)                           | Camille |
| 2007/11/7  | Modify section 2.2.3 (SD card)                                       | Camille |
| 2007/11/15 | Modify chapter 2.2 (Pinter overview)                                 | Camille |
| 2007/11/21 | Add sections 2.6.3 & 2.6.4 (Loading media for peel-off mode /Option) | Camille |
|            |  |         |



TSC Auto ID Technology Co., Ltd.

Headquarters / Factory

No. 35, Sec. 2, Ligong 1st Rd., Wujie Town  
, I-Lan County, Taiwan 268, R.O.C.

TEL: +886-3-990-6677

FAX: +886-3-990-5577

Web site: [www.tscprinters.com](http://www.tscprinters.com)

E-mail: [printer\\_sales@tscprinters.com](mailto:printer_sales@tscprinters.com)

[tech\\_support@tscprinters.com](mailto:tech_support@tscprinters.com)

Taipei Office

11F, No. 205, Sec. 3, Beishin Rd., Shindian City,  
Taipei 231, Taiwan, R.O.C. Taiwan 268, R.O.C.

TEL: +886-2-8913-1308

FAX: +886-2-8913-1808